

E.H. WACHS



E.H. WACHS®

Superior Equipment. Complete Support.™

MACHINE TOOL RENTALS

Ask About
Training
Options



WACHS

FACTORY RENTALS

ehwachs.com



SDSF Small Diameter Split Frame



MDSF Modular Design Split Frame



LDSF Large Diameter Split Frame



EP 424 End Prep

This edition of the E.H. Wachs Factory Rental brochure features a wide array of Wachs weld prep machine tools and accessories designed for use by the professional field machinist. It highlights the complete lineup of Wachs equipment available as factory rentals, including three ranges of split frames with the SDSF, DynaPrep® MDSF and LDSF available in sizes to cover a full .5in to 120in (DN15-3000) OD range of tube, pipe or vessels.

In addition to building the most comprehensive line of split frames offered anywhere, E.H. Wachs factory rentals include our famous Guillotine® pipe saws and the Trav-L-Cutter®, industry favorites that continue to fill the needs of professionals around the globe.

ID mounted end prep machine tools include our class leading EP 424 with its unique, SpeedPrep™ autofeed system, and the proven SDB series that can be converted to FF series flange facers. Wachs RS-2 (rising stem) and P-2 handheld valve operators are available with new options for control and monitoring valve activity.

E.H. Wachs machine tools are the number one choice of field machining experts in these major industries:

- Oil & Gas, used upstream and downstream in oil production, refineries, and petrochemical plants for MRO, turnaround operations, and valve actuation
- Power Generation, used in Fossil, CoGen and Nuclear facilities for carbide and high alloy pipe, tube and main steam lines in MRO and outage applications
- Pipeline Distribution, specialized pipeline kits ideal for the large diameter, thin wall pipe MRO applications including cutting, beveling and transitions
- Shipbuilding, new build and MRO pipe and tubing applications

Our tagline says it all: Superior Equipment. Complete Support. E.H. Wachs is the premier manufacturer of Superior Equipment, leading our industry with innovative pipe cutting and beveling machine tools like the DynaPrep MDSF that redefines cold-cutting equipment. Complete Support is available through our dedicated and knowledgeable sales force, through our customer support and engineering at our headquarters, and at our worldwide Sales, Service and Rental Centers.

Rentals are a cost-effective solution for short-term projects, unique applications or one-time tasks. For larger, major projects our WachsBox rental program allows 24/7 access to a variety of machine tools and tooling.

To learn more or request a quote call 800.323.8185 or visit ehwachs.com



Renting with E.H. Wachs is a fast, cost effective and easy way to get the weld prep machine tools, tooling and accessories when and where you need them. You can submit your rental request online at ehwachs.com, or contact your Wachs product specialist to help you select the right machine for the best results.

Available locally at our regional Sales, Service and Rental Center or shipped direct to your project site, ordering Wachs factory rental equipment is a simple four step process.

Step 1: Identify Your Project Scope.

The first step is identifying the scope of your project: what types of field machining applications, when and where, and (if you know it) project details such as clearances, diameters, material, schedules, prep and drive type. For a quick introduction to some of the more common machine tool applications see Specifying Wachs Equipment, a guide to the Wachs equipment available for each machining task.

Step 2: Select Your Preferred Machine Tool and Drive Type.

Many applications can use more than one type of Wachs machines to complete the field machining project. Additionally, many Wachs machines can be configured to perform multiple operations. One of our more versatile machines, the DynaPrep MDSF, has accessories and modules available to perform most common machining tasks.

Step 3: Select Your Tool Slides or Accessory Modules.

As part of a complete machining system, E.H. Wachs offers multiple choices in tooling, tools slides and modules to perform a given task. While tools such as the Trav-L-Cutter and Guillotine are very straightforward, others such as the split frames and end preps offer a wide range of options, making them suitable for a wide range of projects. Offered as pipeline, flange facing and socket weld removal kits, most kits only require specifying a drive motor and tooling. Ask your Wachs representative for additional details on tool slides and kits.

Step 4: Order Your Tooling.

Tooling is the collective name for consumable items such as saw blades, milling blades, cutting (or parting) bits, facing, slitting and beveling tool bits, plus the newest generation of insert tool bits and holders. Tooling comes in different materials, profiles and coatings, many tailored to specific jobs, so we encourage you to call us to discuss your projects tooling needs. Extra tooling ordered but not used in their original, unopened packages can be returned at the end of the rental for a full credit.

Step 1: Identify the Project



Step 2: Select Your Machine & Drive Type



Step 3: Select Your Tool Slides & Accessories



Step 4: Order Your Tooling

SPECIFYING Wachs Equipment



Pipe Cutting



Pipe Beveling



Counterboring



Flange Facing

A fast way to specify E.H. Wachs rental machines is by the application - from precision weld preps to destructive cutting to specialized tasks, Wachs most likely has a rental machine for the job. Contact your Wachs representative at 800-323-8185 for assistance, or the Sales, Service and Rental Center nearest you. We're here to help.

Pipe Cutting & Beveling

Wachs split frames (or clamshells) are designed for cutting (parting), double parting (utilizing two cutting bits) or simultaneous cutting and beveling. Fast and precise, split frames are available in models to machine from .5 to 120in (DN15-3000) OD and can be configured to bevel, compound bevel, and create J-Preps to your precise specifications.

Other choices include Wachs Trav-L-Cutter®, a milling machine that offers the advantage of fitting any OD by simply adding more mounting chain sections, and the Guillotine® (or "Wachs Saw"), reciprocating pipe saws that cut a wide range of materials.

Pipe Beveling

For pipe beveling on open ended workpieces, Wachs ID mounted end prep machines with self-centering mandrels set up quickly and are easy to use. These include the EP 424 (4in-24in) with available SpeedPrep autofeed, and the SDB series for end prepping pipe from .88in ID to 12.75in OD.

Counterboring

Counterboring is machining the ID of the pipe for transitions, tapers or smoothing, after the weld prep and prior to welding. All Wachs split frames when properly configured produce precise counterbores and deep counterbores, with end prep machines capable of limited counterboring as well.

Flange Facing



















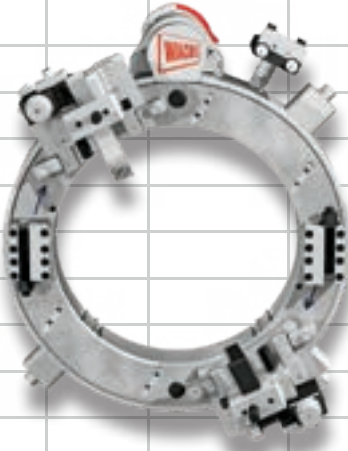



















Wachs DynaPrep MDSF makes an excellent flange facer, with available FFC and FFR modules designed for flat face, raised face, record grooving and machining RTJ groves. The LDSF is ideal for facing of large diameter pipe and vessels. The ID mounted EP 424 can face out to 36in, with the FF series capable of facing from 2in-24in OD.

Specialized Applications

Wachs offers machines and accessories to tackle a wide range of specialized applications, including large diameter vessels and steam generators, heavy wall and high alloy materials, trepanning, weld crown reduction, socket weld removal, and external and internal casing cutting.

Contact Wachs for assistance with your specific application.

OD Mounted Machine Ranges

	1/2in (13mm)	12in (305mm)	24in (610mm)	36in (914mm)	48in (1219mm)	60in (1524mm)	72in (1829mm)	90in (2286mm)	120in (3048mm)
SDSF	SDSF 1.0								
	SDSF 2.0								
	SDSF 3.0								
	SDSF 4.0								
	SDSF 5.0								
	SDSF 6.0								
DYNAPREP MDSF	MDSF 206								
	MDSF 408								
	MDSF 610								
	MDSF 612								
	MDSF 814								
	MDSF 1016								
	MDSF 1218								
	MDSF 1420								
	MDSF 1824								
	MDSF 2228								
	MDSF 2632								
	MDSF 3036								
	MDSF 3642								
	MDSF 4248								
	MDSF 4854								
	MDSF 5460								
	MDSF 6066								
	MDSF 6672								
LDSF	LDSF 75								
	LDSF 90								
	LDSF 105								
	LDSF 120								
TRAV-L-CUTTER	MODEL E (PNEUMATIC)								
	MODEL HE (HYDRAULIC)								
GUILLOTINE	SUPER C								
	MODEL D								
	SUPER D								
	GOLIATH								

SDSF Split Frame

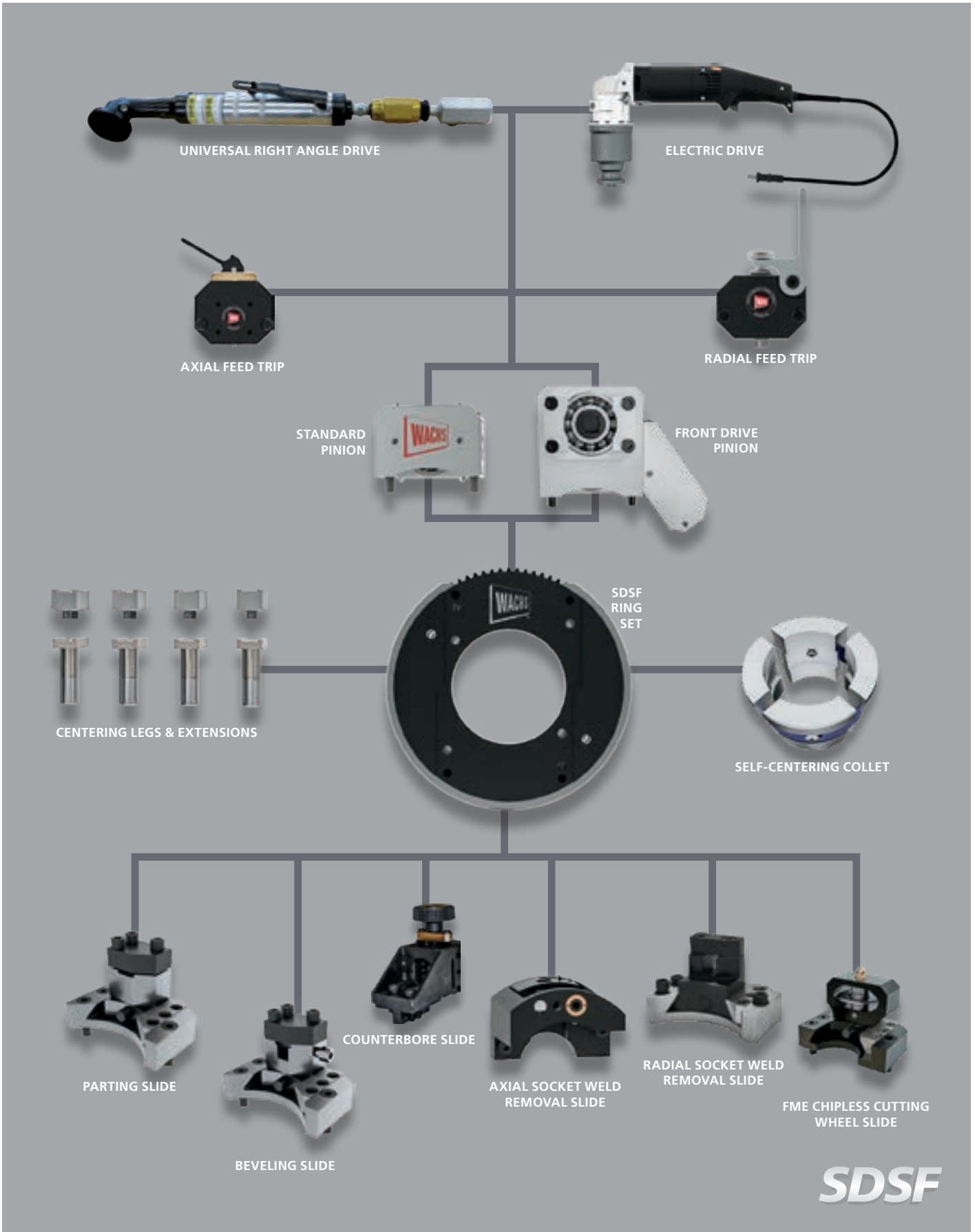

SDSF Split Frame

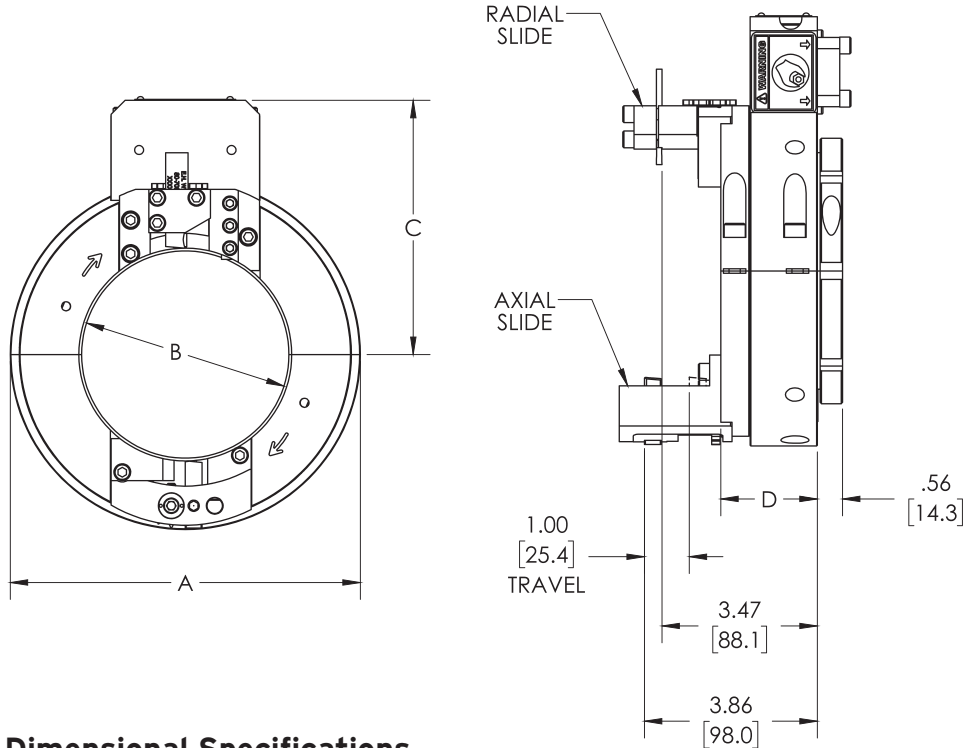

Counterbore attachment fits all models



Axial Socket Weld Removal

Dimensional Specifications

SPECIFICATIONS	SDSF 1.0	SDSF 2.0	SDSF 3.0	SDSF 4.0	SDSF 5.0	SDSF 6.0
Machine Capacity OD	The machine capacity depends on the mounting system and on the operating method.					
"A" Machine OD	5in (127mm)	5.689in (145mm)	6.87in (175mm)	7.815in (199mm)	8.937in (227mm)	9.937in (252mm)
"B" Machine ID	1.563in (40mm)	2.626in (67mm)	3.75in (95mm)	4.752in (121mm)	5.878in (149mm)	6.878in (175mm)
"C" Max Radius	6.69in (170.0mm)	7.54in (191.5mm)	8.66in (220.1mm)	9.59in (243.5mm)	10.79in (274.0mm)	11.72in (297.8mm)
"D" Machine thickness	2.531in (64mm)	2.154in (55mm)				

System Function:

Part off, bevel and counterbore pipe and tube; radial and axial socket weld removal; wheel cutting

Cutting tool surface speed:

10m/min, 2in 40sf/m 4in

Drive options: Pneumatic or electric

Air requirements:

35cfm at 90psi
(1m³/min at 6.2BAR)

Electrical requirements: 230/120V

Feed method: Starwheel

Feed rate: Fixed at 0.0031in (0.079mm) per trip

Tool slide: Radial or axial feed, cut and bevel, counterbore, FME module

Tool stroke: 0.468in (11.9mm)

Tooling: Axial or radial socket weld removal tooling, cut/bevel tooling. High speed steel or carbide

Optional Equipment

- Pneumatic or electric drive motor
- Genuine Wachs Tooling
- Axial feed tool slide
- Radial feed tool slide set
- Bench mount
- Front drive pinion housing
- Counterbore attachment
- FME tool slide
- Aluminum collet sets
- Clamp pads sets
- Radial socket weld slide

Add frames, slides, collets, collet nut and spanner wrench, or clamping feet to complete machine.



SDSF Axial Turning



Wheel Cutting Module for FME Cutting

SDSF Split Frame

Small Size, Big Capabilities

The SDSF is ideal anywhere pipe and tube are arrayed in tight places and finds many uses in power generation, oil and gas and the shipbuilding industries. Operating on air or electric power the SDSF is part of a complete system that includes a broad range of tool slides and accessories for maximum versatility.

Like all Wachs split frames the SDSF is designed to simultaneously cut and bevel pipe and tube. It's also the basis of Wachs specialized Socket Weld Removal kits, in both axial and radial configurations. The FME (Foreign Material Exclusion) chipless cutting module makes the SDSF the perfect split frame for the high purity market. So while the SDSF is Wachs smallest split frame, it's big in capabilities.

ITEM	PIPE OD	PART #
SDSF Split Frame 1.0*	1in (25mm)	R80-4000-10
SDSF Split Frame 2.0	2in (51mm)	R80-4000-20
SDSF Split Frame 3.0	3in (76mm)	R80-4000-30
SDSF Split Frame 4.0	4in (102mm)	R80-4000-40
SDSF Split Frame 5.0**	5in (127mm)	R80-4000-50
SDSF Split Frame 6.0**	6in (152mm)	R80-4000-60
SDSF Parting Tool Slide	1in-6in(25mm-152mm)	R80-4101-XX
SDSF Beveling Tool Slide	1in-6in(25mm-152mm)	R80-4102-XX

* Collet only 1in (25.4mm) and below.

** Special sizes on request

Socket Weld Removal Kits

SDSF split frames are the building block of Wachs socket weld removal machines. They're designed to remove couplers and elbows from existing piping systems by machining away the weld material that joins them. This is done without sacrificing the base material – a vital consideration in the repair or modification of complex process systems. These machines designs incorporate all that we've learned from years of socket weld removal experience. They're the easiest to use and most productive socket weld removal machines offered anywhere.

ITEM	PIPE OD	PART #
SDSF Axial Feed Pneumatic Kit	0.5-2in (12.7-50.8mm)	R80-0000-AX
SDSF Radial Feed Pneumatic Kit	0.5-2in (12.7-50.8mm)	R80-0000-RA

Universal Counterbore Slide

Designed for perfect counterboring of the pipe or tube inside diameter, the universal counterbore fits all Wachs SDSF ring sets.

ITEM	PART #
Universal counterbore slide For SDSF 1.0 to SDSF 6.0	R80-4107-00

Foreign Material Exclusion (FME)

Wachs FME (Foreign Material Exclusion) is a chipless wheel cutting module designed for use with the SDSF. FME is critical in high purity and process applications where the introduction of chip debris cannot be tolerated.

ITEM	PART #
FME (foreign material exclusion) slide	R80-4106-60

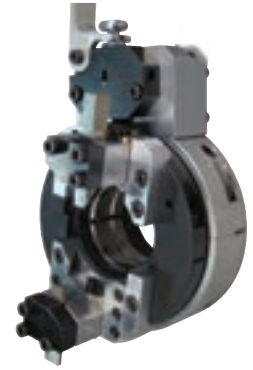

SDSF Small Diameter Split Frame



Cut and Bevel Prep



Socket Weld Removal



SDSF Counterbore Bevel

DynaPrep MDSF Split Frame

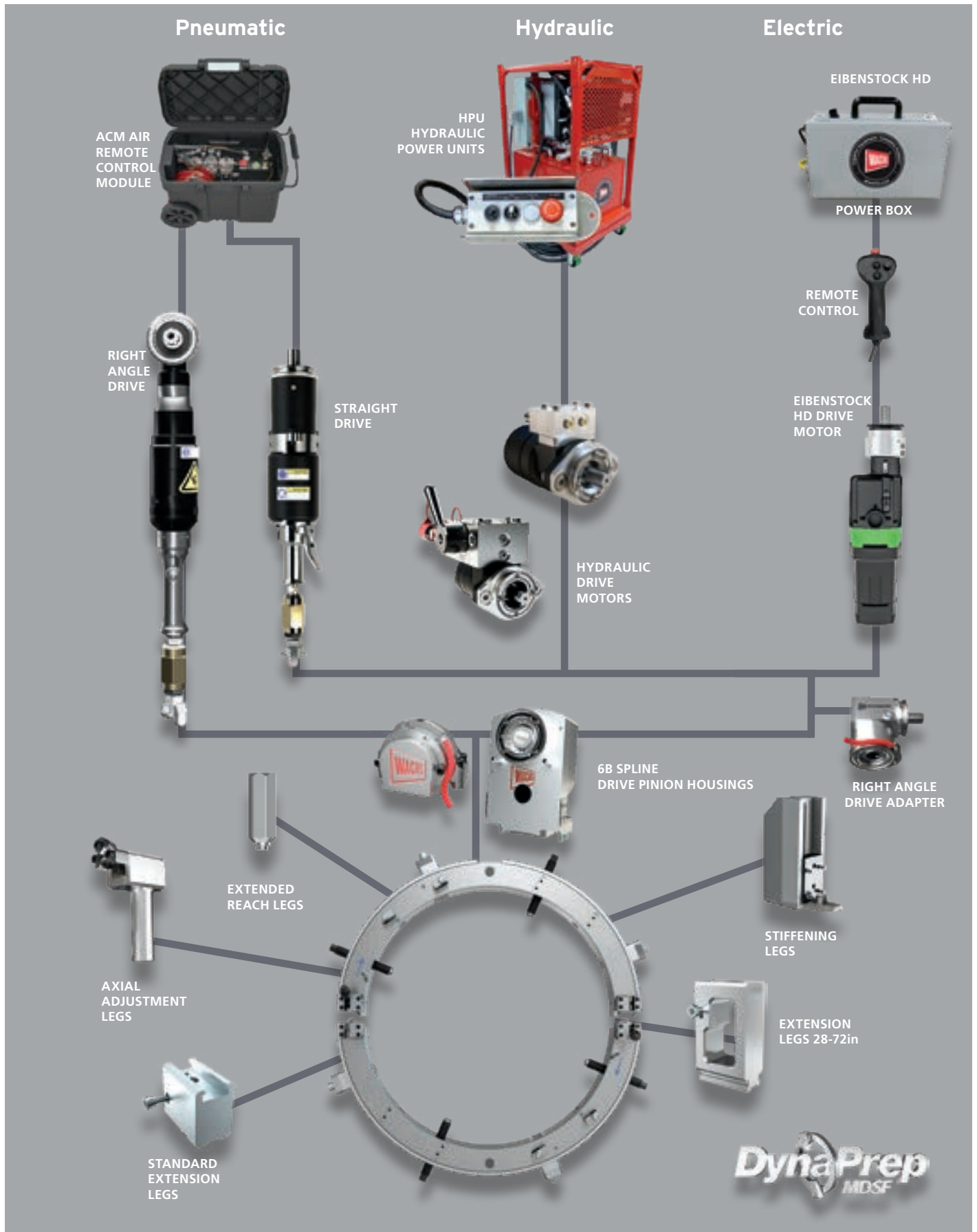

DynaPrep MDSF Split Frame

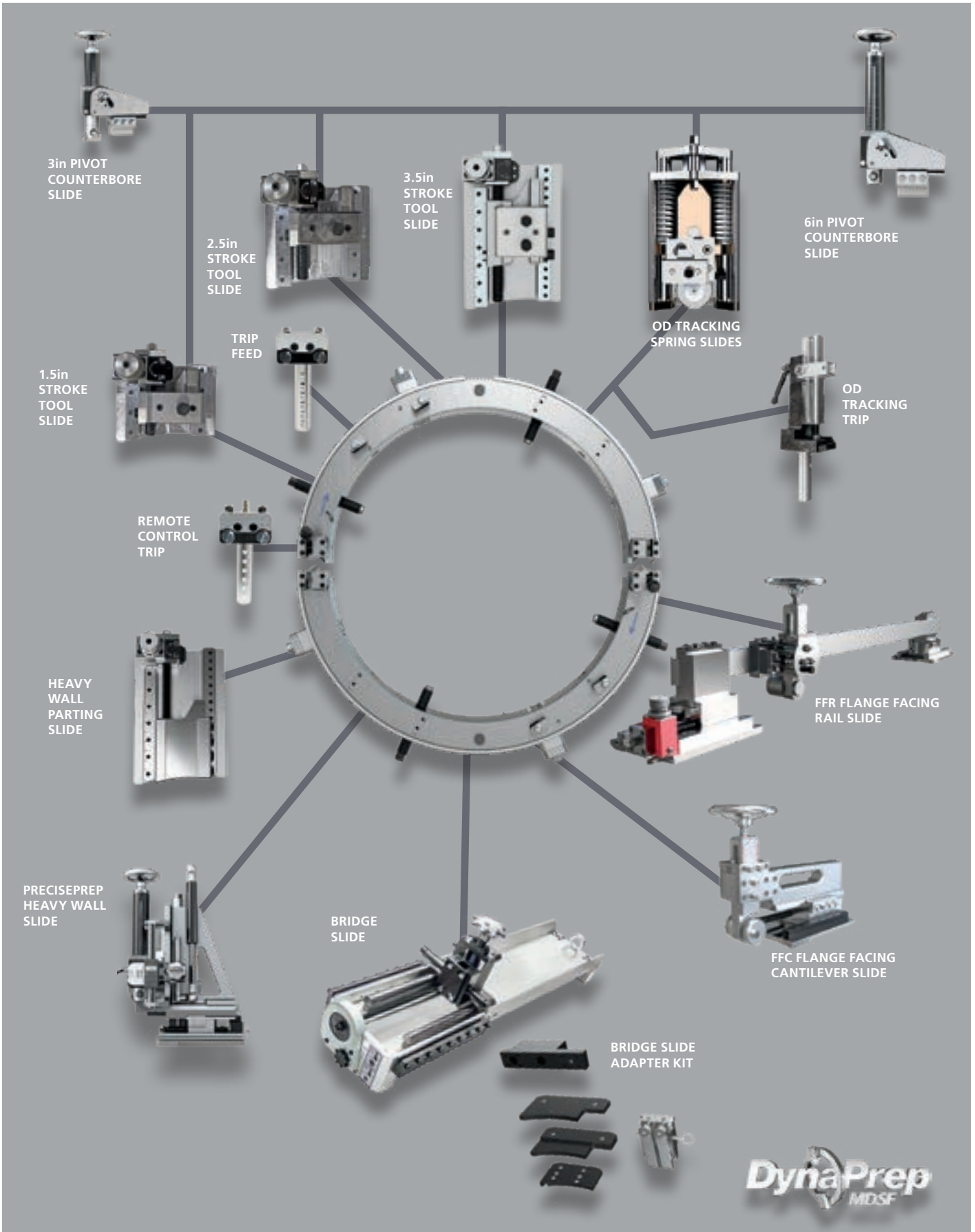

DynaPrep MDSF Split Frame

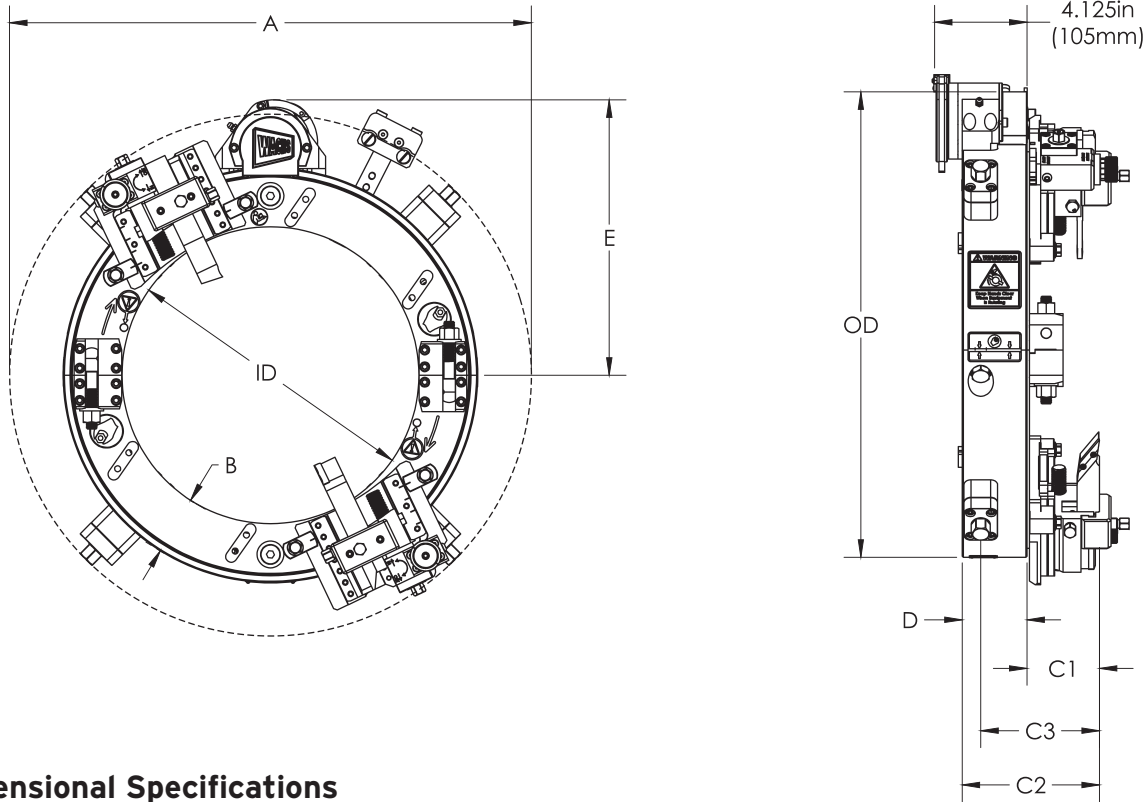

Dimensional Specifications

MODEL	ID	OD	A ROTATING PARTS DIAMETER			B FRAME THICKNESS	MDSF TOOLING		LEGACY TOOLING		C3 CUT LINE TO LEG CENTER	D FRAME DEPTH	E PINION RADIUS STANDARD	PRODUCT WEIGHT		
			1.5IN SLIDES	2.5IN SLIDES	3.5IN SLIDES		C1 CUT LINE TO REAR	C2 CUT LINE TO FRONT	C1 CUT LINE TO REAR	C2 CUT LINE TO FRONT				HALF RING	FULL RING	RING & 2.5IN SLIDES
206	7.25in (184mm)	12.65in (321mm)	17.86in (454mm)	20.2in (513mm)		2.7in (69mm)							9.49in (241mm)	28lb (12.7kg)	54.5lb (24.7kg)	74.9lb (34kg)
408	9.25in (235mm)	14.53in (369mm)	19.8in (503mm)	22.16in (563mm)		2.64in (67mm)							10.49in (266.4mm)	31lb (14.1kg)	57.5lb (26.1kg)	77.9lb (35.3kg)
610	11.25in (286mm)	16.5in (419mm)	21.76in (553mm)	24.12in (613mm)									11.49in (291.8mm)	37lb (16.8kg)	70lb (31.8kg)	90.4lb (41kg)
612	13.25in (337mm)	18.5in (470mm)	23.74in (603mm)	26.1in (663mm)	32.04in (814mm)	2.625in (67mm)							12.49in (317.2mm)	41lb (18.6kg)	77lb (34.9kg)	97.4lb (44.2kg)
814	14.65in (372mm)	19.9in (506mm)	25.16in (639mm)	27.54in (700mm)	33.48in (850mm)		5.375in (136.5mm)		5.125in (130.2mm)		5.29in (134.5mm)	3in (76.2mm)	13.19in (335mm)	44lb (20kg)	81lb (36.7kg)	101.4lb (46kg)
1016	16.65in (423mm)	21.95in (558mm)	27.22in (691mm)	29.6in (752mm)	35.54in (903mm)								14.19in (360.4mm)	47lb (21.3kg)	88lb (39.9kg)	108.4lb (49.2kg)
1218	18.65in (474mm)	23.95in (608mm)	29.28in (744mm)	31.66in (804mm)	37.6in (955mm)	2.65in (67mm)							15.19in (385.8mm)	52lb (23.6kg)	97lb (44kg)	117.4lb (53.3kg)
1420	20.65in (525mm)	25.95in (659mm)	31.3in (795mm)	33.68in (856mm)	39.64in (1007mm)		2.375in (60mm)		2.125in (54mm)				16.19in (411.2mm)	54lb (24.5kg)	103lb (46.7kg)	123.4lb (56kg)
1824	25.05in (636mm)	30.35in (771mm)	35.78in (909mm)	38.16in (969mm)	44.14in (1121mm)								18.39in (467.1mm)	60.5lb (27.4kg)	116.5lb (52.8kg)	136.9lb (62.1kg)
2228	29.05in (738mm)	35.55in (903mm)	39.94in (1015mm)	42.32in (1075mm)	48.3in (1227mm)								20.99in (533.1mm)	92lb (41.7kg)	174.5lb (79.2kg)	194.9lb (88.4kg)
2632	33.05in (840mm)	39.55in (1005mm)	43.92in (1116mm)	46.3in (1176mm)	52.28in (1328mm)								22.99in (583.9mm)	101lb (45.8kg)	191.5lb (86.9kg)	211.9lb (96.1kg)
3036	37.65in (956mm)	44.15in (1121mm)	48.56in (1233mm)	50.94in (1294mm)	56.94in (1446mm)	3.25in (83mm)							25.29in (642.4mm)	115lb (52.2kg)	218lb (98.9kg)	238.4lb (108.1kg)
3642	43.65in (1109mm)	50.15in (1274mm)	54.54in (1385mm)	56.94in (1446mm)	62.92in (1598mm)		5.625in (142.9mm)		5.375in (136.5mm)		5.54in (140.8mm)	3.25in (82.6mm)	28.29in (718.6mm)	127lb (57.6kg)	246lb (111.6kg)	266.4lb (120.8kg)
4248	49.65in (1261mm)	56.15in (1426mm)	60.52in (1537mm)	62.92in (1598mm)	68.9in (1750mm)								31.29in (794.8mm)	139.5lb (63.3kg)	271lb (122.9kg)	291.4lb (132.2kg)
4854	56.05in (1424mm)	63.75in (1619mm)	66.9in (1699mm)	69.3in (1760mm)	75.3in (1913mm)	3.85in (98mm)							34.99in (888.7mm)	174lb (78.9kg)	344lb (156kg)	364.4lb (165.3kg)
5460	62.05in (1576mm)	69.75in (1772mm)	72.9in (1852mm)	75.3in (1913mm)	81.28in (2065mm)								38.99in (990.3mm)	190lb (86.2kg)	375lb (170.1kg)	395.4lb (179.4kg)

DynaPrep MDSF Kits

Simplified Ordering

As part of a complete machining system, the modular design of the MDSF allows different modules to extend its capabilities to include multiple applications such as flange facing, casing cutting, trepanning, and deep counterboring. Like all E.H. Wachs split frames it comes complete with a heavy duty storage case. All of our drive motors feature our tool-less quick mount system with positive face gear engagement.

DynaPrep MDSF Base Kits

The DynaPrep MDSF Base Kit includes most commonly specified components. Less expensive and easier than ordering components ala carte, these base model MDSF Kits are ideal where multiple ring sizes are required onsite.

Highly upgradeable, these kits feature 1.5in stroke tool slides on sizes up to 10in, 2.5in stroke tool slides on sizes up to 48in, and 3.5in stroke tool slides on the larger ring sizes. All machines in this group offer a large range of optional tool slides.

These kits are complete, just add a drive motor and tooling.

MDSF BASE KITS	OPERATING RANGE	PART #
Model 206	2-6in (51-152mm)	R69-5400-06
Model 408	4-8in (102-203mm)	R69-5400-08
Model 610	6-10in (152-254mm)	R69-5400-10
Model 612	6-12in (152-305mm)	R69-5400-12
Model 814	8-14in (203-356mm)	R69-5400-14
Model 1016	10-16in (254-406mm)	R69-5400-16
Model 1218	12-18in (305-457mm)	R69-5400-18
Model 1420	14-20in (356-508mm)	R69-5400-20
Model 1824	18-24in (457-610mm)	R69-5400-24
Model 2228	22-28in (559-711mm)	R69-5400-28
Model 2632	26-32in (660-813mm)	R69-5400-32
Model 3036	30-36in (762-914mm)	R69-5400-36
Model 3642	36-42in (914-1067mm)	R69-5400-42
Model 4248	42-48in (1067-1219mm)	R69-5400-48
Model 4854	48-54in (1219-1372mm)	R69-5400-54
Model 5460	54-60in (1372-1524mm)	R69-5400-60
Model 6066*	60-66in (1524-1676mm)	R69-5400-66
Model 6672*	66-72in (1676-1829mm)	R69-5400-72

DynaPrep MDSF Pipeline Base Kits

DynaPrep MDSF Pipeline Base Kits are configured with the components typically specified in pipeline MRO operations. Large diameter thin wall pipe used in pipelines tend to be out-of-round, which makes precision weld preps with standard tool slides problematic. Wachs included out-of-round spring tool slides track the outside of the pipe to maintain a perfect land and prep. These slides allow a 12in operating range.

These kits are complete, just add a drive motor and tooling.

MDSF BASE KITS	OPERATING RANGE	PART #
Model 612	4-12in (102-305mm)	R69-5405-12
Model 814	4-14in (102-356mm)	R69-5405-14
Model 1016	4-16in (102-406mm)	R69-5405-16
Model 1218	6-18in (152-457mm)	R69-5405-18
Model 1420	8-20in (203-508mm)	R69-5405-20
Model 1824	12-24in (305-610mm)	R69-5410-24
Model 2228	16-28in (406-711mm)	R69-5410-28
Model 2632	20-32in (508-813mm)	R69-5410-32
Model 3036	24-36in (610-914mm)	R69-5410-36
Model 3642	30-42in (762-1067mm)	R69-5410-42
Model 4248	36-48in (914-1219mm)	R69-5410-48
Model 4854	42-54in (1067-1372mm)	R69-5410-54
Model 5460	48-60in (1219-1524mm)	R69-5410-60
Model 6066†	54-66in (1372-1676mm)	R69-5410-66
Model 6672‡	60-72in (1524-1829mm)	R69-5410-72

Perfect for most pipeline applications, with an optional right angle drive available. Like all DynaPrep MDSF machines, their modular design means a machine configured for pipeline projects can be reconfigured for multiple applications, including deep counterboring and flange facing, making them highly versatile machines.

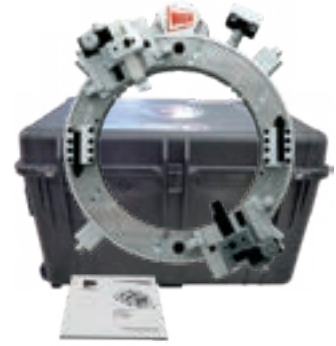

DynaPrep MDSF Kit with pneumatic straight drive motor



Base Kits come complete, just add drive motor and tooling



DynaPrep MDSF Pipeline are specially configured for MRO on thin wall, large diameter pipe



Available in sizes for 4-72in (102-1829mm) pipe

DynaPrep MDSF Tool Slide Options

Multiple features including Rapid Adjust & Micro Adjust tool depth. Standard, dedicated standard, high feed and deep counterboring options.

ITEM	PART #
Low Clearance Cutting & Beveling Worm Slide Kit** .003in Feed & 1.5in Stroke	R69-5215-03
Standard Cutting & Beveling Worm Slide Kit** .003in Feed & 2.5in Stroke	R69-5225-03
Extended Cutting & Beveling Worm Slide Kit** .003in Feed & 3.5in Stroke.	R69-5255-03
Low Clearance Cutting & Beveling Worm Slide Kit** .006in Feed & 1.5in Stroke.	R69-5215-06
Standard Cutting & Beveling Worm Slide Kit** .006in Feed & 2.5in Stroke	R69-5225-06
Extended Cutting & Beveling Worm Slide Kit** .006in Feed & 3.5in Stroke	R69-5255-06
OD Tracking Slide Kit 12-60in	R69-5204-01
Deep Counter Bore Slide Assembly. 3in Depth.	R69-4605-00
Deep Counter Bore Slide Assembly. 6in Depth.	R69-4606-00
Heavy Wall Parting Slide Kit .003in Feed & 3.50in Stroke	R69-5235-03
Heavy Wall Parting Slide Kit .006in Feed & 3.50in Stroke	R69-5235-06
PrecisePrep Tool Slide for Single Pointing and Heavy Wall Counterbore	CALL
Bridge Slide for SF 612, SF 814*	R60-428-14
Bridge Slide for SF 612, SF 814, SF 1016*	R60-428-16
Bridge Slide for SF 612, SF 814, SF 1016, SF 1218, SF 1420*	R60-428-20
Bridge Slide for SF 1218, SF 1420, SF 1824*	R60-428-24
Bridge Slide for SF 1824, SF 2228*	R60-428-28
Bridge Slide for SF 2228, SF 2632*	R60-428-32
Bridge Slide for SF 2632, SF 3036*	R60-428-36
Bridge Slide for SF 3642*	R60-428-42
Bridge Slide for SF 3642, SF 4248*	R60-428-48
MDSF Bridge Slide Adapter Kit	R69-5300-00
37.5° Bridge Slide Template	R53-409-02
30° Bridge Slide Template	R53-409-03
20° Bridge Slide Template	R53-409-05
10° X 37.5° Bridge Slide Template	R53-409-11
10° X 30° Bridge Slide Template	R53-409-12
10° X 20° Bridge Slide Template	R53-409-13

*REQUIRES MDSF ADAPTER KIT, ORDERED SEPARATELY. **TRIP NOT INCLUDED

DynaPrep MDSF Pinion Housings

ITEM	MOUNT	PART #
1/2in Female to 6b Spline Male Adapter	1/2in (12.7mm) Square	R69-3037-00
Spline Drive Pinion Standard (Tool Free)	6B Spline	R69-4484-00
Spline Drive Pinion Front Drive (Tool Free)		R69-4481-01

DynaPrep MDSF Trip & Throttle Assemblies

ITEM	PART #
MDSF Pneumatic Dual Trip-Remote	R69-4741-00
MDSF Trip Assembly Manual	R69-4740-00
MDSF Trip Assembly for 3.5in Slides	R69-4742-00
Pneumatic Trip Housing Assembly 4in-20in LCSF & MDSF	RSPG-620-401
Pneumatic Trip Housing Assembly 24in-48in LCSF & MDSF	RSPG-620-410
Remote Trip Housing & Throttle Assembly 4in-20in LCSF & MDSF	RSPG-620-415
Remote Trip Housing & Throttle Assembly 24in-48in LCSF & MDSF	RSPG-620-416

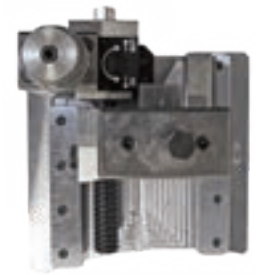

DynaPrep MDSF 2.5in Stroke Slide

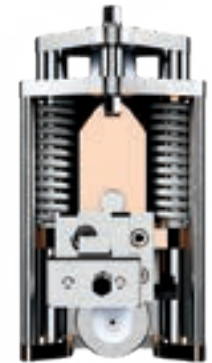

DynaPrep MDSF OD Tracking Slide for out-of-round pipe



Bridge Slide for Single Pointing, Flange Facing, and Heavy Wall



PrecisePrep Tool Slide for Single Pointing and Heavy Wall Counterbore

Air Treatment & Control

The Air Control Module (ACM) provides remote operation capability for select models of Wachs pneumatic powered machines, allowing operators to cut and bevel pipe up to 26 feet (7.9 m) away.

ITEM	PART #
ATM Air Treatment Module with Shipping Case (non-CE compliant) SUPERSEDES P/N (26-407-00). REQUIRED FOR USE WITH "CONTROL HANDLE" AIR MOTORS ONLY.	R69-4102-01
ACM Air Control Module & Remote Trip Kit (CE Compliant) REQUIRED FOR "NO CONTROL HANDLE" AIR MOTORS	R69-4100-00
ACM Air Control Remote REQUIRED FOR USE WITH "NO CONTROL HANDLE" AIR MOTORS	R69-4101-01
ATM Air Treatment Caddy (Non-CE)	R26-407-00



ACM controlling Split Frame

Pneumatic Drive Motor Kits

E.H. Wachs offers a wide variety of power drive options including electric, hydraulic and pneumatic.

ITEM	PART #
Pneumatic Right Angle Drive Motor w/Speed Control, Chicago Fitting, and ACM Air Control Module	R69-5454-00
Pneumatic Right Angle Drive Motor w/Control Handle, Speed Control, Chicago Fitting, and ATM Air Treatment Module	R69-5452-00
Pneumatic Right Angle Drive Motor w/Control Handle, Speed Control, Oiler, Filter, and Chicago Fitting	R69-5450-00
Pneumatic Straight Drive Motor w/Speed Control, Chicago Fitting, and ACM Air Control Module	R69-5455-00
Pneumatic Straight Drive Motor w/Control Handle, Speed Control, Chicago Fitting, and ATM Air Treatment Module	R69-5453-00
Pneumatic Straight Drive Motor w/Control Handle, Speed Control, Oiler, Filter, and Chicago Fitting	R69-5451-00
Right Angle Adapter for Pneumatic Straight Drive Motors	R69-4359-00
Pneumatic Reversible Right Angle Drive Motor w/Handle	R69-4353-01



Air Motors

Hydraulic Drive Motors

Tong-free connection allows the motor's 6B spline drive and face gear to slide into place, providing fast setup.

DESCRIPTION	PART #
Universal Hydraulic Drive Motor with Flow control	R69-4358-00
Universal Hydraulic Drive Motor without Flow Control	R69-4363-01
EP 424 Hydraulic Drive Motor	R81-310-00
SDB / FF Hydraulic Drive Motor	R56-413-03



Hydraulic drive motors

Electric Drive Motors

Smooth, quiet, and powerfully efficient they pack a large amount of power in a relatively compact package.

DESCRIPTION	PART #
Eibenstock HD Electric Drive-110V, MDSF	R69-4340-00
Eibenstock HD Electric Drive-220V, MDSF	R69-4341-00
Eibenstock HD Electric Drive-110V w/remote pendant (requires controller)	R69-4342-00
Eibenstock HD Electric Drive-220V w/remote pendant (requires controller)	R69-4343-00
Eibenstock HD 110v w/remote pendant, electric remote trip, controller	R69-4344-00
Eibenstock HD 220v w/remote pendant, electric remote trip, controller	R69-4345-00
Eibenstock Drill-style Electric Drive Assembly-110V	RSPG-489-4110
Eibenstock Drill-style Electric Drive Assembly-220V	RSPG-489-4220



Provides electric power with remote control options available

DynaPrep MDSF Flange Facing

FFC Flange Facing Cantilever Kit

E.H. Wachs new FFC flange facing is ideal where an MDSF is already onsite for pipe cutting and beveling. This kit adds counterboring capabilities and advanced flange facing and record grooving capabilities without the need for heavy and expensive dedicated facers.

The FFC module is used on flat face, raised face and applications where the FFR rail cannot be accommodated, such as heat exchangers. It will machine 500 RMS, 250 RMS, 125 RMS and 63 RMS record groove finishes, plus machining of the smooth bolt face finish. Setting up the DynaPrep for flange facing is fast and easy with its Axially Adjustable Legs featuring removable guides to quickly square the machine to the bolt face. Two FFC modules will simultaneously machine multiple surfaces in a single pass (as shown).

ITEM	PART #
MDSF Flange Facing Cantilever Kit, 12in	R69-FFC-12
MDSF Flange Facing Cantilever Kit, 14in	R69-FFC-14
MDSF Flange Facing Cantilever Kit, 16in	R69-FFC-16
MDSF Flange Facing Cantilever Kit, 18in	R69-FFC-18
MDSF Flange Facing Cantilever Kit, 20in	R69-FFC-20
MDSF Flange Facing Cantilever Kit, 24in	R69-FFC-24
MDSF Flange Facing Cantilever Kit, 28in	R69-FFC-28

ITEM	PART #
MDSF Flange Facing Cantilever Kit, 32in	R69-FFC-32
MDSF Flange Facing Cantilever Kit, 36in	R69-FFC-36
MDSF Flange Facing Cantilever Kit, 42in	R69-FFC-42
MDSF Flange Facing Cantilever Kit, 48in	R69-FFC-48
MDSF Flange Facing Cantilever Kit, 54in	R69-FFC-54
MDSF Flange Facing Cantilever Kit, 60in	R69-FFC-60

FFR Flange Facing Rail Kit

The FFR module for flat face, raised face, and RTJ grooved flanges, machines 500 RMS, 250 RMS, 125 RMS and 63 RMS record groove finishes, plus it can machine the smooth bolt face finish and counterbore. The rail module's advanced design is adjustable in multiple axes to machine RTJ ring grooves.

Setting up the DynaPrep for flange facing is fast and easy with axially adjustable legs that feature removable guides to quickly square the machine to the bolt face. A single FFR module can machine the bolt face and record groove in two operations, or optionally two modules can be used to simultaneously machine multiple surfaces in a single pass (as shown) or machine RTJ grooves in half the time.

ITEM	PART #
MDSF Flange Facing Rail Kit, 16in	R69-FFR-16
MDSF Flange Facing Rail Kit, 18in	R69-FFR-18
MDSF Flange Facing Rail Kit, 20in	R69-FFR-20
MDSF Flange Facing Rail Kit, 24in	R69-FFR-24
MDSF Flange Facing Rail Kit, 28in	R69-FFR-28
MDSF Flange Facing Rail Kit, 32in	R69-FFR-32

ITEM	PART #
MDSF Flange Facing Rail Kit, 36in	R69-FFR-36
MDSF Flange Facing Rail Kit, 42in	R69-FFR-42
MDSF Flange Facing Rail Kit, 48in	R69-FFR-48
MDSF Flange Facing Rail Kit, 54in	R69-FFR-54
MDSF Flange Facing Rail Kit, 60in	R69-FFR-60

CONVERTS
DYNAPREP MDSF
TO A FLANGE
FACER



FFC Flange Facing Cantilever Module



Two FFC modules simultaneously machine bolt face & record groove

FACES AND
MACHINES RTJ
RING GROOVES

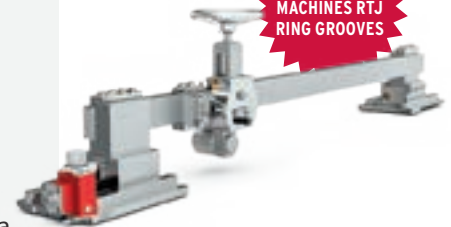

FFR Flange Facing Rail Module



Two FFR modules performing simultaneous operations

ECC External Casing Cutter Kits

Precision External Cutting

Wachs ECC External Casing Cutter Kit utilizes our proven DynaPrep MDSF Split Frame technology to cut a wide range of casing conductors externally above the wellhead. The ECC split frame mounts around the exposed casing OD above the wellhead requiring minimal axial and radial clearances. It simultaneously cuts and chamfers prior to fitting the BOP. Ring sizes are available for most grades and weights of the exposed external casing (or drive pipe/conductor).

The ECC takes advantage of the wide range of standard Genuine Wachs Tooling. The ECC kit includes a right angle pneumatic drive, ATM Air Treatment Module and Front Drive Pinion Housing. Remote hand held controls via the ACM Air Control Module are optionally available.

ECC kits are available in four ring sizes standard ring sizes, featuring interchangeable tool slides and machine drives to cut and bevel all wellhead casing grades, sizes and weights from 4.5in to 13 3/8in OD (with larger sizes available by special order). The ECC is portable, compact, lightweight and requires minimal axial and radial clearance. A single operator can setup and machine the casing for minimal open time.

ECC External Casing Cutter Features

- External casing (drive pipe/conductor) cutting and beveling
- Utilizes standard Wachs Genuine Tooling for severing and chamfering
- Based on Wachs field proven DynaPrep MDSF Split Frame technology
- Requires minimal axial and radial clearances; hydraulic or pneumatic drive

Specifications

Cutting Tool Surface Speed:
60ft. per minute (18mpm)

Drives: Pneumatic, Hydraulic

Air Requirements:
70cfm @ 80-100psi
(2cmm @ 5.6-7 Bar)

Hydraulic Requirements:
8gpm @ 1500psi (30lpm @ 103Bar)

Feed Method: Star wheel feed

Feed Rate: Fixed @.0026in per revolution
(starwheel)

- DynaPrep MDSF Base Kit
- Front Mount Pinion Housing
- Right Angle Pneumatic Drive Motor
- ATM Air Treatment Module
- Fitted Storage Case
- Operating Manuals & Tools

Accessories

- Extension legs
- Inverted Tool Slides
- Tooling (standard and custom)

Standard Equipment

Casing/Conductor Cutting Range Chart

CASING SIZE	SPLIT FRAME SIZE	4.5IN (114MM)	5IN (127MM)	5.5IN (140MM)	6 5/8IN (168MM)	7IN (178MM)	7 5/8IN (194MM)	8 5/8IN (219MM)	9 5/8IN (244MM)	10 3/4IN (273MM)	11 3/4IN (298MM)	13 3/8IN (340MM)	PART #
ECC MDSF 8	4-8in (102-203mm)												R69-5420-08
ECC MDSF 10	6-10in (152-254mm)												R69-5420-10
ECC MDSF 12	6-12in (152-305mm)												R69-5420-12
ECC MDSF 14	8-14in (203-356mm)												R69-5420-14



Simultaneously cuts & bevels casing



ECC can be used inverted for cut lines close to the flange



ECC low clearance design fits into tight operating envelope



Dedicated DuoEdge Casing Cutting Tool Holder & Insert

EICC External / Internal Casing Cutter Kits

External / Internal Precision Cutting

Wachs EICC External Internal Casing Cutter Kit is designed to cut and chamfer the casing internally below the wellhead required for specific BOP installations. It is used in combination with an ECC Kit, which makes the external cut required before installing the EICC. Once the external cut is made, the MDSF split frame from the ECC Kit serves as the drive platform for the EICC.

A wellhead adaptor is required to mount the MDSF, either our Universal adapter or a custom adapter built to your specifications, serving as the mounting point between the wellhead and the MDSF. The EICC is assembled to the MDSF and lowered into the casing, and can be configured to cut down to a depth of 60in (1524mm). A reversing air motor is required and part of the EICC Kit, run forward to advance the tooling, then backwards to retract the tooling prior to extraction and completion.

Features

- Cuts up to 7in through 13 3/8in API casing.
- Utilizes standard Wachs Genuine Tooling for external severing and chamfering
- Optional specialized casing cutter tooling holder and inserts available
- Cutting platform uses the Wachs field-proven DynaPrep MDSF Split Frame
- Requires minimal axial and radial clearances; requires pneumatic reversible drive motor

SPECIFICATIONS

Mounting System	Three-leg, universal chuck
Tool Slides	Standard (7in-9 5/8in) extended range 10 3/4in-13 3/8in mechanical starwheel feed
Counter	Mechanical/rotation
Tooling	Insert & holder/chamfer
Radial Travel	.63" (16mm) radial travel per slide
Wall Capacity	Can cut up to 5/8" wall thickness
Feed Rate	.0047"/rev (.1058mm/rev)
Power	Pneumatic

Machining Capacity

COMPATIBLE SPLIT FRAME	OD CASING SIZE	SPLIT FRAME SIZE	PART #
Model 814	7in - 9 5/8in (177.8 - 244.475mm)	8-14in (203.2-355.6mm)	R69-4815-14
Extended Tool Slide Kit	10 3/4in - 13 3/8in (273 - 339.7mm)	8-14in (203.2-355.6mm)	R60-4001-01

Casing/Conductor Cutting Range Chart

CASING SIZE	4.5IN (114MM)	5IN (127MM)	5.5IN (140MM)	6 5/8IN (168MM)	7IN (178MM)	7 5/8IN (194MM)	8 5/8IN (219MM)	9 5/8IN (244MM)	10 3/4IN (273MM)	11 3/4IN (298MM)	13 3/8IN (340MM)	16IN (406MM)	18 5/8IN (473MM)	20IN (508MM)	24IN (610MM)	26IN (660MM)
7in - 9 5/8in																
10in - 13 3/8in																

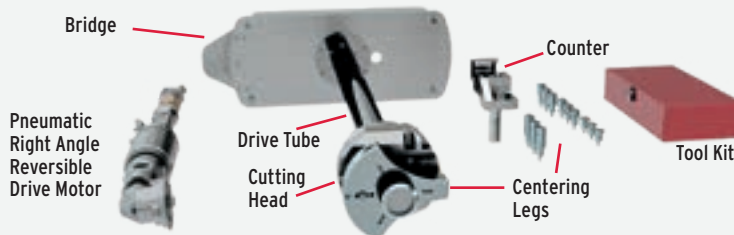

Size range includes most popular casing conductor sizes



EICC Internal Casing Cutter used for wellhead completion



Internal cutting module lowered to cutting depth



MDSF EICC Internal Cut

LDSF Split Frame

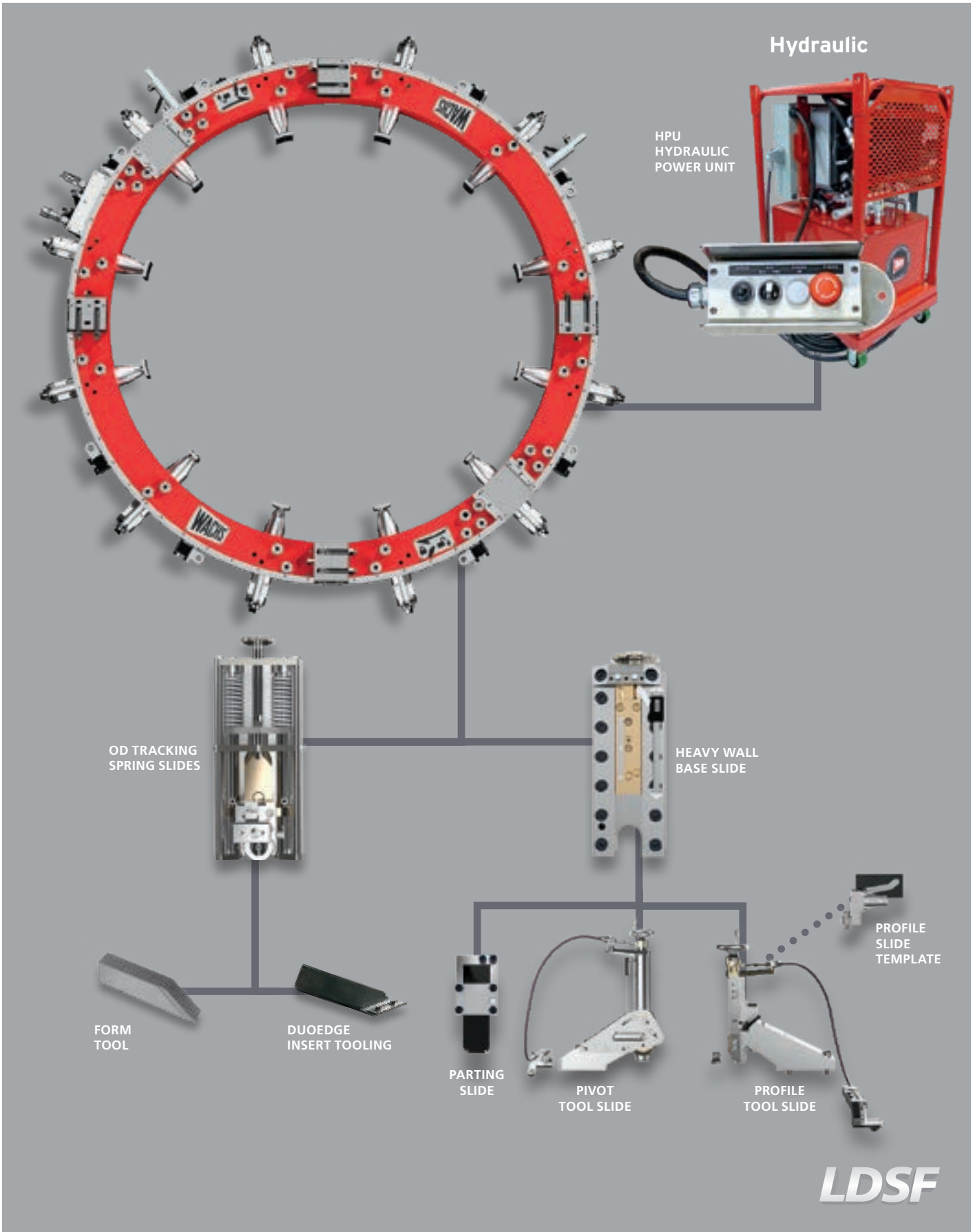

LDSF Large Diameter Split Frame

The internal, full bearing construction contributes to the LDSF's smooth operation and long service life. Spring loaded OD tracking slides for irregularly shaped or out-of-round pipe and vessels are standard, and allow the tooling to maintain continuous contact, producing precision weld preps with consistent lands. The LDSF takes corrosion protection to a new level with virtually every surface treated. Its attractive red powder coated finish proudly reflects E.H. Wachs famous red and black corporate colors.

LDSF Modules and Slide Kits

New modules and kits broaden the versatility of the LDSF. Pivot Slide and Profile Slide kits allow for deep counterboring and heavy wall (up to 6in or 152mm) single point machining and profiling. A new flange facing adapter kit allows the LDSF to perform facing on very large diameter flanges. A new double parting kit allows for faster severing on even the heaviest wall or high alloy materials.

OD Tracking Slide

Standard equipment and included with the LDSF, the OD Tracking Slide is extremely versatile and suitable for typical applications including parting and beveling, and includes spring loaded trips to eliminate feed crashes. Utilizes standard Legacy and DynaPrep MDSF tooling.

Pivot Slide Kit

The LDSF Pivot Slide Kit is designed for ID or OD turning, facing and beveling. It's ideal for large diameter vessels, including steam generators, used in oil and gas and power generation applications. Used for extra heavy wall applications (up to 6in) with greater metal removal requirements on ID and OD profiles.

Profile Slide Kit

The LDSF Profile Slide Kit is a multipurpose slide that can be configured to bevel heavy wall pipe and vessels and face large diameter flanges. The Profile Slide utilizes standard and custom made interchangeable templates to perform precise compound bevels.

Parting Slide Kit

The LDSF Parting Kit features digital read out (DRO) for precise radial position indication. This module is designed for parting and beveling configurations.

Heavy Wall Base Slide

The LDSF Heavy Wall Base Slide serves as the mounting platform for the Parting Kit, Pivot Slide and Profile Slide Kits.

ITEM	PART #
60in-75in LDSF Split Frame	R12-042-5100-75
75in-90in LDSF Split Frame	R12-042-5100-090
90in-105in LDSF Split Frame	R12-042-5100-105
105in-120in LDSF Split Frame	R12-042-5100-120
LDSF Pivot Slide Kit	R12-042-4442-00
LDSF Profile Slide Kit	R12-042-4443-00
LDSF Template for Profile Slide Kit	R12-042-4445-00
LDSF Parting Kit	R12-042-4441-01
LDSF Heavy Wall Base Slide	R12-042-4440-00



OD Tracking Slide



Pivot Slide Kit



Profile Slide Kit



Parting Kit



Heavy Wall Base Slide



Template for Profile Slide Kit

LDSF Split Frame

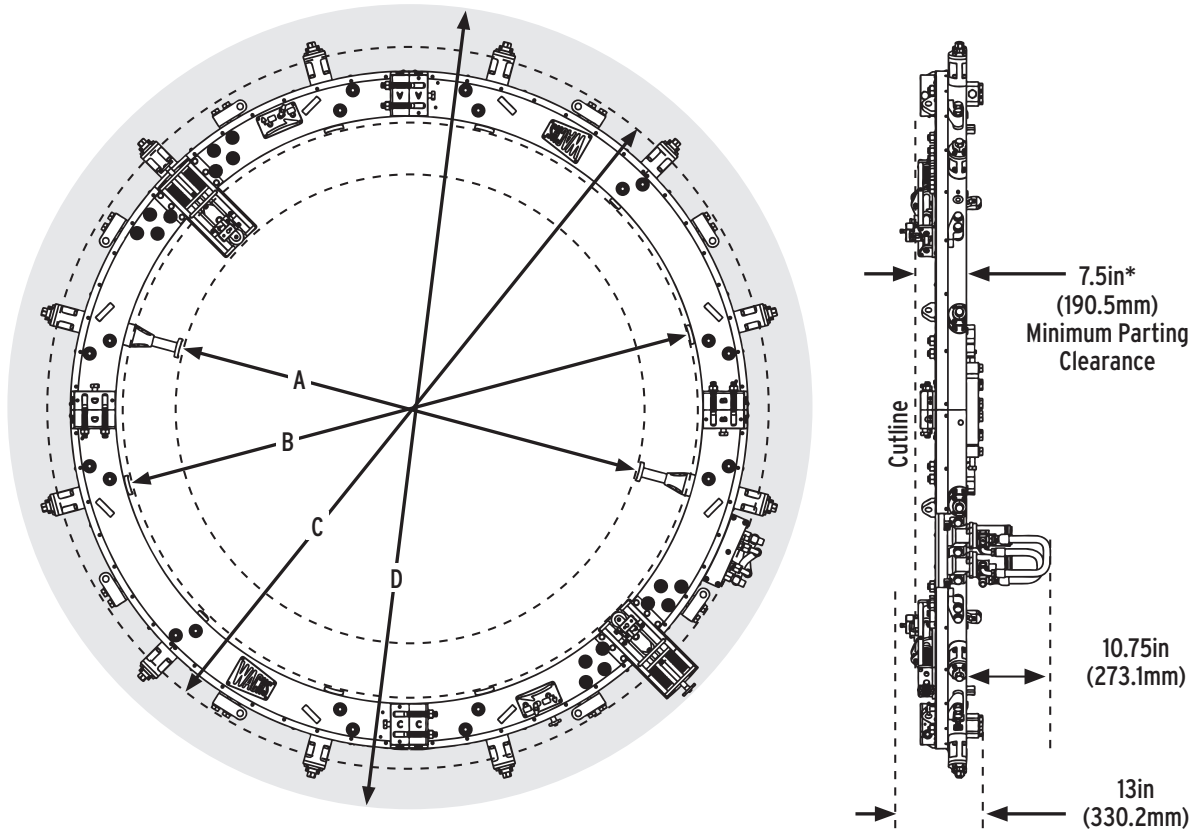

SPECIFICATIONS	LDSF 75	LDSF 90	LDSF 105	LDSF 120
Dimension "A - B" Machine capacity range (Nominal Pipe Size)	60-75in (1524-1905mm)	75-90in (1905-2286mm)	90-105in (2286-2667mm)	105-120in (2667-3048mm)
Dimension "C" pinion clearance	99in (2515mm)	114in (2896mm)	129in (3277mm)	144in (3658mm)
Dimension "D" Standard OD Tracking slide clearance	111in (2820mm)	126in (3200mm)	141in (3581mm)	156in (3962mm)
Dimension "D" Optional Heavy Wall Base Slide clearance	117in (2972mm)	132in (3353mm)	147in (3734mm)	162in (4115mm)

Heavy Wall Insert Holders

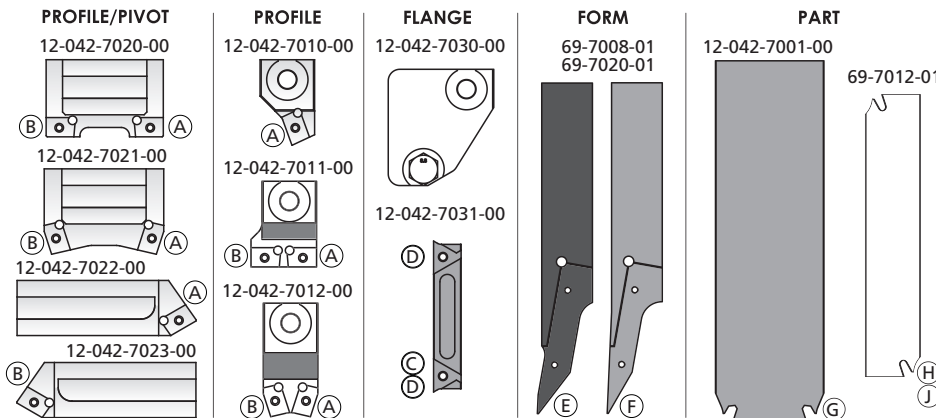

Heavy Wall Insert Tooling

- (A) 12-042-7710-10 (10-pack)
- (B) 12-042-7711-10 (10-pack)
- (C) 12-042-7730-10 (record 10-pack)
- (D) 12-042-7731-10 (facing 10-pack)
- (E) 69-7008-02 (10/37.5°)
- (F) 69-7020-02 (10/30°)
- (G) 12-042-7701-10 (9mm 354gr 10-pack)
- (H) 69-7013-10 (8mm 328gr 10-pack)
- (J) 69-7014-10 (9mm 328gr 10-pack)

TRAV-L-CUTTER

Portable Milling

Fast & Accurate

Wachs high-performance cutters remove 3/16in (4.8mm) of metal while cutting, leaving the pipe end with a smooth, machined finish. The chain feed system maintains continuous out-of-round compensation while providing constant drive under all conditions for accurate cuts. By using an optional guide track and special guide track wheels, higher accuracy can be maintained. This cutting method facilitates section removal in the field where new sections, precut by the same method, can be easily dropped into place.

Operates Anywhere

The Trav-L-Cutter operates on horizontal or vertical pipe, in the field or the shop.

Machines Most Materials

Materials such as carbon steel, ductile iron, cast iron and most alloys in all pipe sizes from 6in to 72in (152.4-1829mm) can be cold cut and beveled simultaneously.

Trav-L-Cutter Features

- Safe cold cutting
- Simultaneous cutting and beveling
- Compact design, easy set-up
- Horizontal and vertical cutting
- Mounts to larger diameters with additional chain

ITEM	MODEL	DRIVETYPE	PIPE OD	PART #
Trav-L-Cutter	E	Pneumatic	6-72* (152-1829*)	R02-000-01
Trav-L-Cutter	HE	Hydraulic	6-72* (152-1829*)	R02-000-02
Trav-L-Cutter Guide Track				R02-428-XX



Model HE Hydraulic



Model E Pneumatic

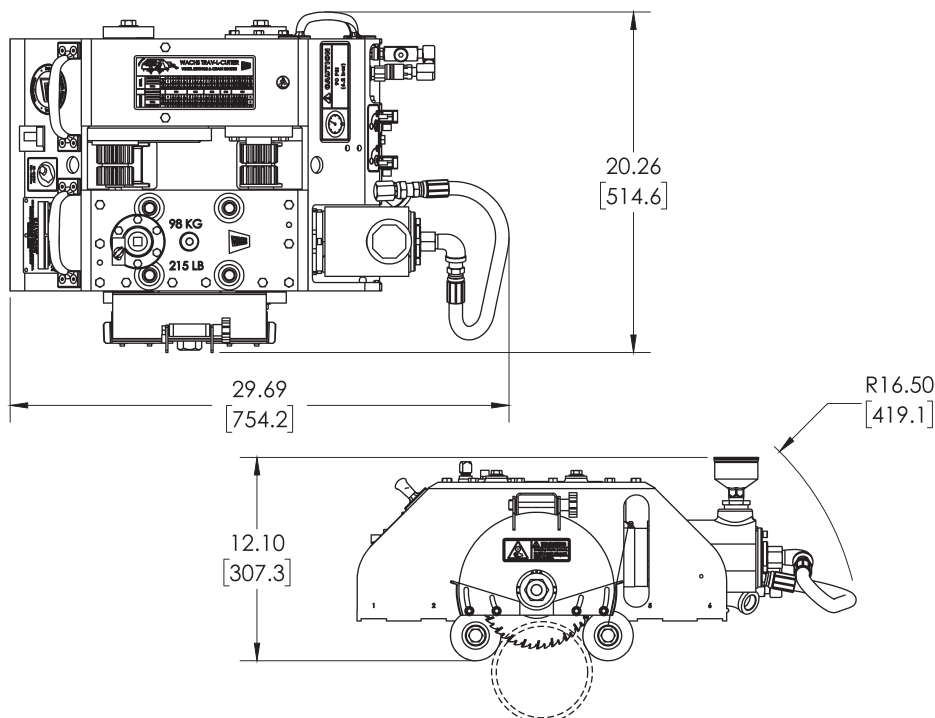

Trav-L-Cutter accommodates large diameters by adding chain sections



First generation Trav-L-Cutter photo circa 1952

GUILLOTINE Saw

Super C, Model D, Super D

- Rugged yet compact design requires minimal clearances
- Four models cut from 2in - 24in (DN 50-600)
- Fast setup and cutting, both horizontally or vertically
- Pneumatic, hydraulic and electric drive options
- Optional autofeed and autoclamping on select models

Easy setup, vertical or horizontal

A chain pipe clamps the Guillotine Saw to the pipe. The machined cast iron "V"-saddle base assures square cuts at right angles. It can be mounted on horizontal as well as vertical piping. Wachs Guillotine saws require minimal clearance (the model Super C needs as little as 1.5in (38.1mm) on one side of the pipe). All models feature finger tip feed control. A 6in (152.4mm) standard wall steel pipe is cut in only 6 minutes. A 16in (406.4mm) diameter 0.5in (12.7mm) wall steel pipe is cut in about 20 minutes.

DESCRIPTION	PIPE OD	PART #
Super C Pneumatic	2-12in (DN 50-300)	R24-000-02
Super C Hydraulic	2-12in (DN 50-300)	R24-000-03
Super C Autoclamp Hydraulic	2-12in (DN 50-300)	RP06-150-502
Super C Autoclamp & Autofeed Hydraulic	2-12in (DN 50-300)	RP06-150-500
Model D Pneumatic	6-18in (DN 150-457)	R04-000-02
Model D Hydraulic	6-18in (DN 150-457)	R04-000-03
Super D Pneumatic	10-24in (DN 250-610)	R25-000-01
Super D Hydraulic	10-24in (DN 250-610)	R25-000-03
Super D Autoclamp Hydraulic	10-24in (DN 250-610)	RP06-150-512
Super D Autoclamp & Autofeed Hydraulic	10-24in (DN 250-610)	RP06-150-510

Machine Dimensions

DIMENSIONS	SUPER C	MODEL D	SUPER D
Pipe OD	2-12in (DN 50-300)	6-18in (DN 150-450)	10-24in (DN 250-600)
Solids through	12.75in (324mm)	18.625in (473mm)	24.5in (622mm)
Clearance overall width	28in (711mm)	32in (813mm)	39in (991mm)
Clearance on one side min.	2.5in (63.5mm)	3in (76mm)	3in (76mm)
Operating Weight	115lb (52kg)	340lb (154kg)	515lb (234kg)
Shipping Weight	180lb (82kg)	415lb (188kg)	620lb (281kg)
Dimension A	23.5in (596,9mm)	31.25in (794mm)	38.25in (972 mm)
Dimension B	12.75in (323,85mm)	14.5in (368mm)	14.5in (368mm)
Dimension C	31.5in (800mm)	37in (940mm)	44in (1118mm)
Dimension D	13.25in (337mm)	18.75in (476mm)	24.75in (629mm)
Stroke	2in (51mm)	2in (51mm)	4in (102mm)
Shipping dimensions (estimated)	26in x 29in x 22in (66cm x 74cm x 56cm)	63in x 47in x 29in (160cm x 119cm x 74cm)	CALL









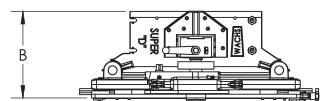
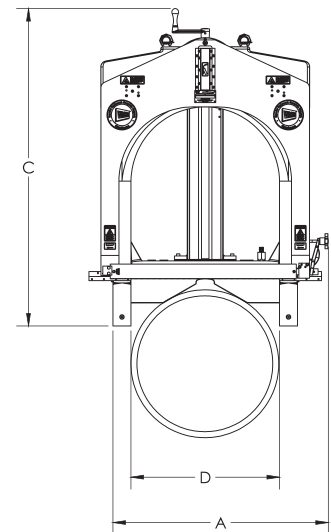









Guillotine Super C



Elliptical cutting action, long blade life



ID Mounted Machine Ranges

	1/2in (13mm)	4in (102mm)	8in (203mm)	12in (305mm)	16in (406mm)	24in (610mm)	36in (914mm)	
EP 424 END PREP	EP 424 FORM TOOLING							
	EP 424 SINGLE POINTING							
SDB SMALL DIAMETER BEVELER	SDB 103							
	SDB 206							
	SDB 412							
FF FLANGE FACER	FF 206							
	FF 313							
	FF 424							

EP 424 End Prep

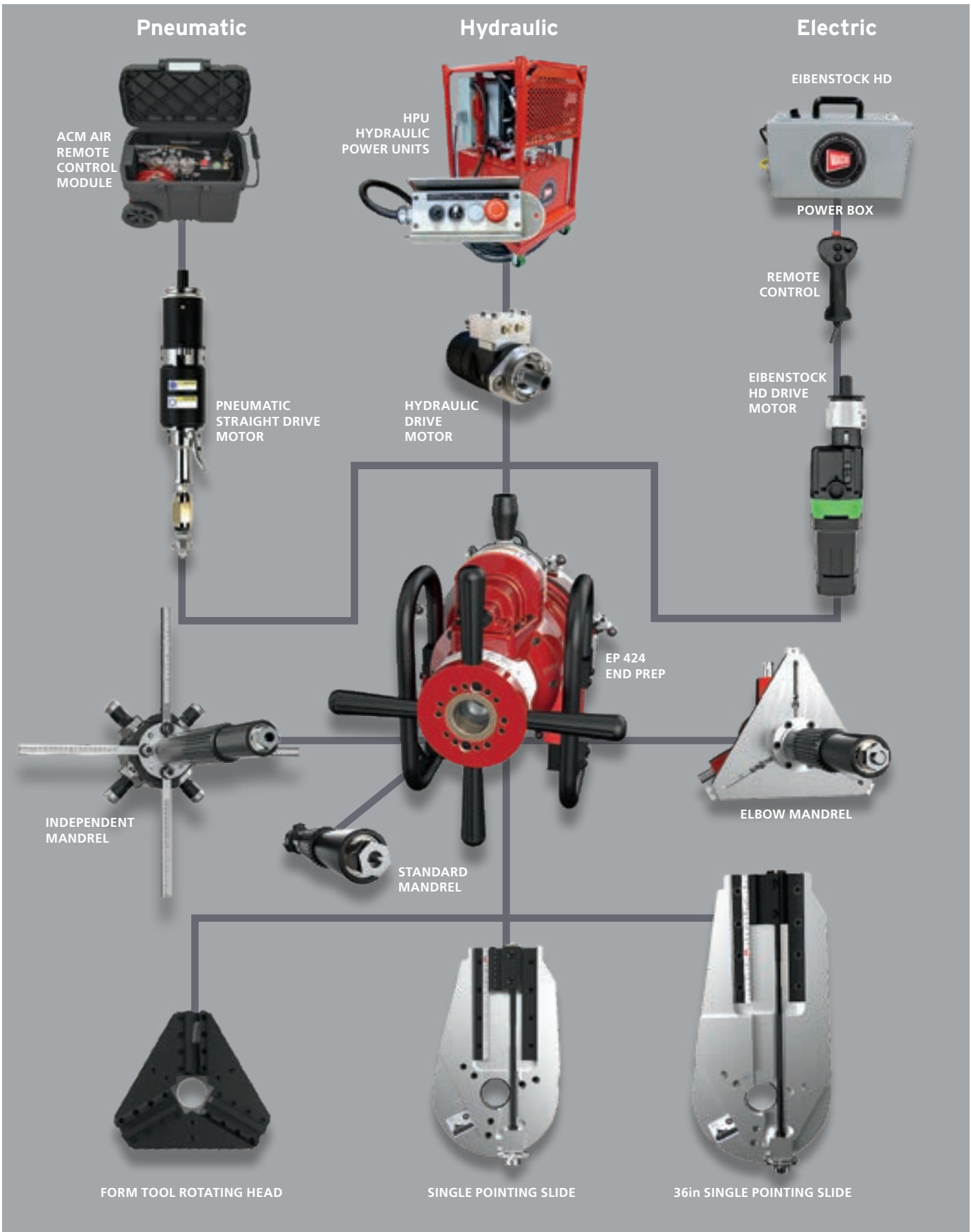

EP 424 End Prep

81-000-01 Form Tool Basic Pneumatic

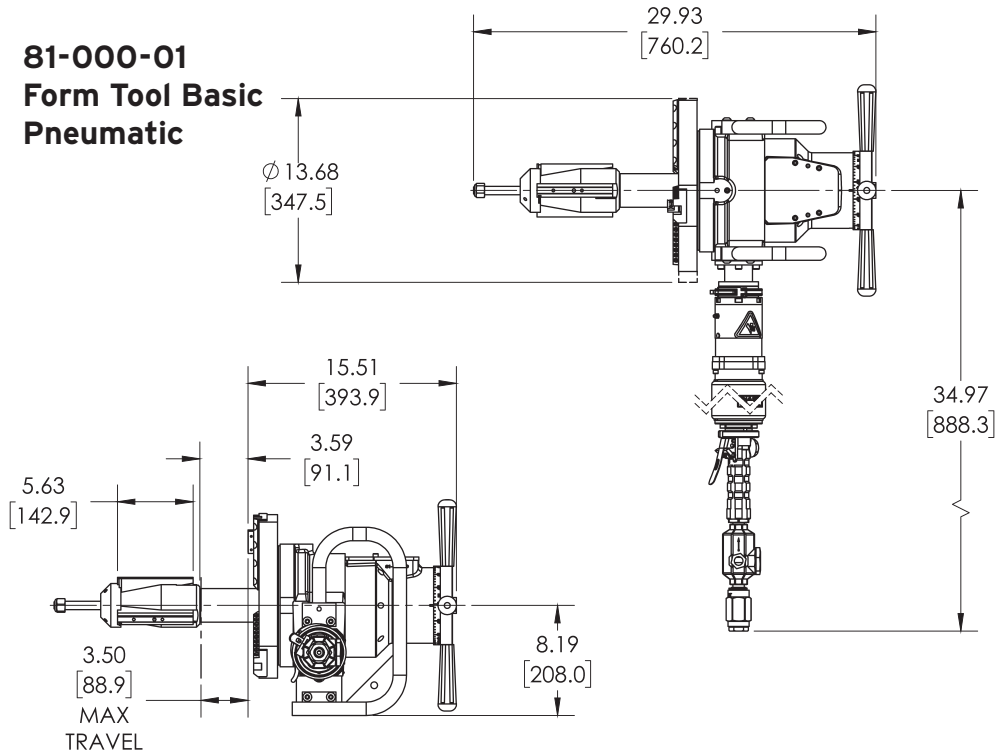

EP 424 SpeedPrep™ deluxe beveling with form tool rotating head



EP 424 SpeedPrep™ deluxe prepping heavy wall pipe

81-000-05 SpeedPrep Deluxe Pneumatic

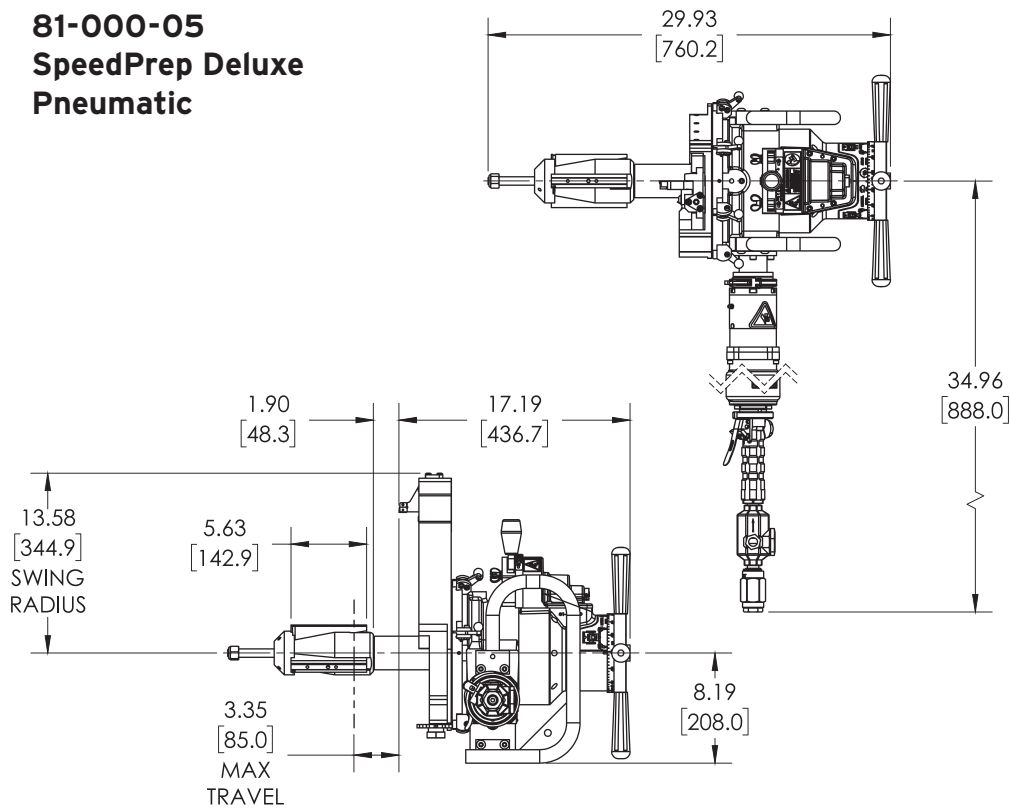

Self-centering standard mandrel



Independent Mandrel

EP 424 Kits

EP 424 Form Tool Basic			EP 424 SpeedPrep™ Deluxe			EP 424 SpeedPrep™ Premium			
PNEUMATIC DRIVE	HYDRAULIC DRIVE	ELECTRIC DRIVE ADAPTER	PNEUMATIC DRIVE	HYDRAULIC DRIVE	ELECTRIC DRIVE ADAPTER	PNEUMATIC DRIVE	HYDRAULIC DRIVE	ELECTRIC DRIVE ADAPTER	
			Form Tooling Rotating Head Assembly 4-16in OD (102-406mm)						
				Single Point Slide ID 4.24-24in OD (108-610mm)					
			Standard Self-Centering Mandrel ID 3.27-15.96in (83-405mm)						
				Standard Self-Centering Mandrel ID 14.87-23.64in (378-600mm)					
						Independent Mandrel ID 8.5-22.6in (215.9-574mm)			
			SpeedPrep™ AutoFeed						
PART #	R81-000-01	R81-000-02	R81-000-07	R81-000-05	R81-000-06	R81-000-09	R81-000-03	R81-000-04	R81-000-08



EP 424 Flange Facing with single point machine slide



Cross section of EP 424 mounted for single pointing



EP 424 Single Point Deluxe with form tooling rotating head



Faces flanges up to 36in (914mm) with optional slide

With Wachs AutoFeed system on the EP 424, it's now possible to dial in the exact prep needed for your application. Select the bevel angle and the land that works best for your application, without work stoppages or additional components. More versatile and powerful than any other machine of its kind, the Wachs EP 424 sets the standard in user friendly large diameter end prep machines.

Features

- Safe cold cutting process, eliminates heat affected zone
- Lathe machining delivers precise compound bevels and consistent lands
- EP 424 eliminates the need for accessory templates or external tool slides
- Fast setup and prep with standard self-centering mandrel legs
- Fully enclosed bearings and drive gears for safety and durability
- Low friction bearing system provides maximum stability, eliminating chatter

Design Capabilities

- Machine perfect preps from OD 4in - 24in (DN100 - 600)
- Form tool pipe from OD 4in - 14in (DN 100-350)
- Single point machining from OD 8in - 24in (DN 100-600)
- Single point Up to 36in (DN 900) with optional slide
- Fully modular construction for one man setup and operation

ITEM	PART #
10in-24in Independent Chuck for EP-424	R81-305-00
3-Leg Chuck for EP-424. 3.75in-20in I.D	R81-315-00
EP-424 4in-16in Rotating Head Assembly. Form Tool	R81-304-00
EP-424 4in-24in Single Point Slide	R81-306-00
EP-424 Pneumatic Motor Assembly	R81-311-00

SDB Small Diameter Bevelers

E.H. Wachs® SDB line of small diameter bevelers have been engineered for fast, precise onsite facing, beveling, compound beveling and counterboring of light and heavy wall pipe, tube or casing. Proven workhorses, they set up quickly with a self centering mandrel and chuck assembly mounting to the pipe I.D. Their highly productive design means one person can setup, operate and create a perfect weld prep in minutes.

SDB 103/3 Pipe End Prep Beveler

Face, bevel and counterbore simultaneously on carbon, stainless and high alloy steels. Machine boiler tubes, heavy wall pipe and thick wall tubing. Prep elbows and face flanges* using only one machine. Fast, accurate weld preps on pipe and tube from 0.875in I.D. through 4.5in O.D. (22.2 mm – 114 mm) and flanges 2in I.D. (50.8 mm) through 6in O.D. (152.4 mm)

DESCRIPTION	DRIVE TYPE	PIPE ID TO OD	PART #
SDB 103	Pneumatic	0.88-4.5in (22-114mm)	R16-000-01
SDB 103	Electric 110 V, 50 Hz	0.88-4.5in (22-114mm)	R16-000-02
SDB 103	Electric 220 V, 50 Hz	0.88-4.5in (22-114mm)	R16-000-03

SDB 206/2 Pipe End Prep Beveler

Bevel, counterbore, face and compound bevel pipe and tube from 1.91in I.D. through 6.625in O.D. (48.5 mm – 168 mm) and face flanges* from 3in I.D. through 13in O.D. (76.2 mm – 330.2 mm), regardless of material wall thickness. Only a 2.25in (57 mm) radial clearance is required.

DESCRIPTION	DRIVETYPE	PIPE ID TO OD	PART #
SDB 206/2	Pneumatic	1.91-6.63in (49-168mm)	R56-000-01
SDB 206/2	Electric 110 V, 50 Hz	1.91-6.63in (49-168mm)	R56-000-02
SDB 206/2	Electric 220 V, 50 Hz	1.91-6.63in (49-168mm)	R56-000-04
SDB 206/2	Hydraulic	1.91-6.63in (49-168mm)	R56-000-03

SDB 412/2 Pipe End Prep Beveler

Heavy-duty and compact. Designed to face, bevel, compound bevel and counter bore 3.80in I.D. through 12.02in O.D. (96.5 mm – 305.3 mm) pipe or tube, up to 1.125in (29 mm) wall thickness and face flanges* 4in I.D. through 24in O.D (101.6 mm through 609.6 mm).

DESCRIPTION	DRIVETYPE	PIPE ID TO OD	PART #
SDB 412/2	Pneumatic	3.8-12.75in (97-324mm)	R66-000-01
SDB 412/2	Hydraulic	3.8-12.75in (97-324mm)	R66-000-03
SDB 412/2	Electric 220 V, 50 Hz	3.8-12.75in (97-324mm)	R66-000-02

***Need a Flange Facer? Ask about the SDB to FF Flange Facer Conversion Kit for your rental project.**



SDB to FF Conversion Kit: head, mandrel, legs, & fasteners

SDB Small Diameter Bevelers

Machine Dimensions

DIMENSIONS	SDB103/3	SDB206/2	SDB412/2
A Rotating Head Diameter	4.75in (120.7mm)	7.00in (177.8mm)	13.30in (337.8mm)
B Mandrel Length	16.75in (425.5mm)	18.41in (467.6mm)	22.97in (583.4mm)
C Housing Diameter	3.19in (81.0mm)	5.08in (128.9mm)	9.12in (231.7mm)
D Chuck	1.28in (32.6mm)	1.96in (49.7mm)	2.45in (62.3mm)
E Rotating Head to Chuck	5.29in (134.5mm)	6.44in (163.5mm)	8.48in (215.3mm)
F Rotating Head Depth	.75in (19.1mm)	1.52in (38.6mm)	1.52in (38.6mm)
G Plunge Depth (Max Travel)	3.36in (85.3mm)	3.00in (76.3mm)	3.95in (100.2mm)
H Drawbar Nut	.94in (23.9mm)	1.12in (28.3mm)	1.12in (28.3mm)
J Mandrel Center to Motor	20.70in (525.7mm)	22.16in (563.0mm)	23.98in (609.0mm)

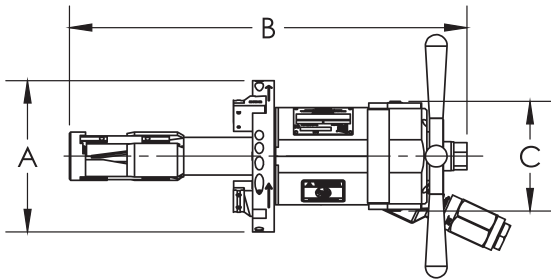
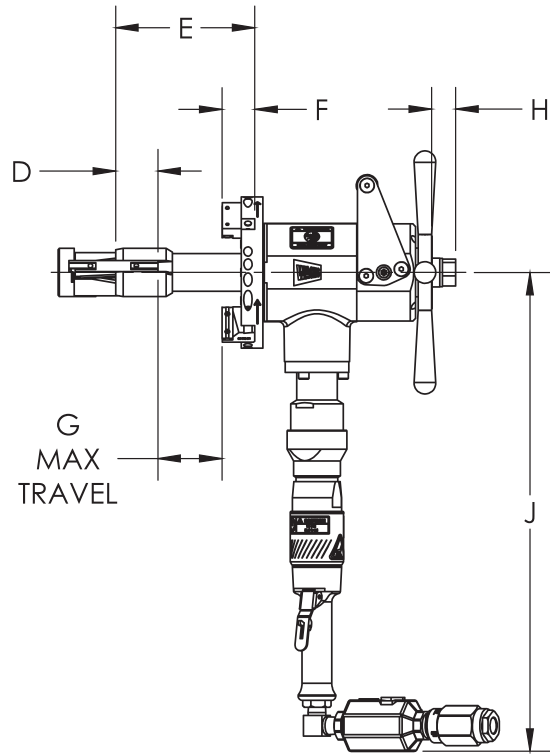

FF Flange Facers

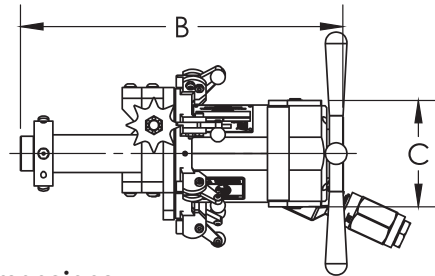
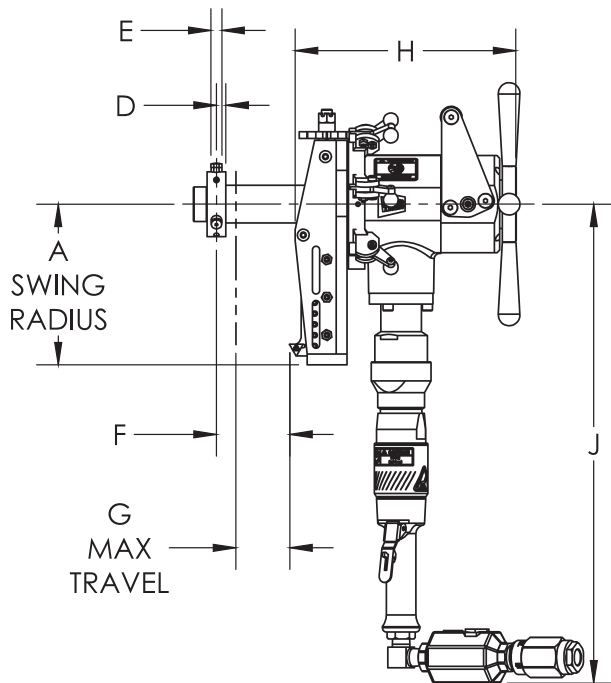

Machine Dimensions

DIMENSIONS	FF206	FF313	FF424
A Slide Swing Radius	6.63in (168.3mm)	8.04in (204.3mm)	12.08in (306.9mm)
B Mandrel Length	14.27in (362.4mm)	14.92in (379.0mm)	17.66in (448.7mm)
C Housing Diameter	3.19in (81.0mm)	5.08in (128.9mm)	9.12in (231.7mm)
D Leg thickness	.33in (8.3mm)	.44in (11.1mm)	.63in (15.9mm)
E Chuck thickness	.38in (9.5mm)	.50in (12.7mm)	.75in (19.1mm)
F Slide to Chuck Depth	3.76in (95.5mm)	3.38in (85.9mm)	4.80in (122.0mm)
G Plunge Depth (Max Travel)	4.86in (123.5mm)	3.14in (79.8mm)	4.44in (112.8mm)
H Handle to Slide Depth	9.86in (250.4mm)	10.40in (264.2mm)	10.91in (277.1mm)
J Mandrel Center to Motor	23.83in (605.2mm)	27.79in (705.9mm)	30.57in (776.4mm)

FF Flange Facers

Now anyone can produce a lathe quality surface finish on flat, raised or recessed face flanges in minutes. Based on the powerful Wachs SDB series ID mount end prep machines, the Wachs FF series flange facers offer a rugged yet lightweight and compact design that allows them to fit into tight quarters. With the addition of the SDB conversion kit, the FF models can be converted into SDB series machines, allowing them to face, bevel, compound bevel and counterbore.

FF 206 Flange Facer

Cuts lathe quality surface finishes on flat and raised face flanges in minutes (Record Groove, RMS 500, 250, 125 & 63). These lightweight and compact machines setup quickly and convert to powerful beveling systems. Flanges 2in I.D. (50.8 mm) through 6in O.D. (152.4 mm).

MODEL	DRIVETYPE	PIPE ID TO OD	PART #
FF 206	Pneumatic	2-6in (50.8-152.4mm)	R16-000-FF
FF 206	Electric 110 V, 50 Hz	2-6in (50.8-152.4mm)	ON REQUEST
FF 206	Electric 220 V, 50 Hz	2-6in (50.8-152.4mm)	ON REQUEST

FF 313 Flange Facer

Flange facing machine for facing raised and flat face flanges from 3in I.D. through 13in O.D. (76.2 mm I.D. through 330.2 mm O.D.). Single point heavy wall pipe 1in (25.4 mm) and greater.

MODEL	DRIVETYPE	PIPE ID TO OD	PART #
FF 313	Pneumatic	3-13in (76.2-330.2mm)	R56-000-FF
FF 313	Electric 110 V, 50 Hz	3-13in (76.2-330.2mm)	ON REQUEST
FF 313	Electric 220 V, 50 Hz	3-13in (76.2-330.2mm)	ON REQUEST
FF 313	Hydraulic	3-13in (76.2-330.2mm)	ON REQUEST

FF 424 Flange Facer

Flange facing machine for facing raised and flat face flanges from 4in I.D. through 24in O.D. (101.6 mm I.D. through 609.4 mm O.D.). Single point heavy wall pipe 1in (25.4 mm) and greater.

MODEL	DRIVETYPE	PIPE ID TO OD	PART #
FF 424	Pneumatic	4-24in (101.6-609.6mm)	R66-000-FF
FF 424	Electric 110 V, 50 Hz	4-24in (101.6-609.6mm)	ON REQUEST
FF 424	Electric 220 V, 50 Hz	4-24in (101.6-609.6mm)	ON REQUEST
FF 424	Hydraulic	4-24in (101.6-609.6mm)	R66-000-FH
FF 424	SDB 412/2 + FF 424 (Set)	4-24in (101.6-609.6mm)	R66-000-04

Ask your Wachs representative about accessories and tooling for your project.



FF 206 Flange Facer



FF 313 Flange Facer



FF 424 Flange Facer



SDB 206 / FF 313
Mandrel Kit

HANDHELD Valve Operators

RS-2 Rising Stem Valve Turner & Operator

The RS-2, designed with operator safety in mind, spares arm and back injuries associated with manually turning large, stubborn or frozen industrial valves. The RS-2 offers a range of adapters and accessories to suit most applications, including PIV (Post Indicator Valves). There's a 1in (25.4mm) square drive adapter, dedicated handwheel adapters and a universal handwheel adapter to fit most common handwheels.

DRIVE TYPE	POWER REQUIREMENTS	MOTOR CONTROLS	PART #
Pneumatic	60cfm @ 90psi	Variable speed; Forward and reverse dial	R78-000-03
Electric	110volt AC (15amps or 3500 watt generator)	Variable speed; Adjustable torque control Forward and reverse control valve	R78-000-01
Hydraulic	8gpm @ 1800psi	Variable speed; Adjustable torque control Forward and reverse control valve	R78-000-04

RS-2 Handwheel Adapter

For using the rising stem valve operator with standard handwheels.

MODEL	PART #
RS2 Dedicated Handwheel Adapter - Stays on handwheel for quick operation	RP13-017-4007-00
RS2 Universal Handwheel Adapter	RP13-017-4008-00

P-2 Handheld High Speed or High Torque Valve Operator

The P-2 (Pow-R-Drive 2) handheld valve turning machine is the ideal solution for organizations dealing with critical valves of any sort, including fire prevention and water material handling systems. It's lighter, faster and more powerful than any other machine of its kind and helps eliminate arm and back injuries associated with attempting to manually turn large or stuck valves.

DRIVE TYPE	TORQUE	SPEED	PART #
Electric 110V	500 ft-lb	20 rpm	R11-000-07
Electric 220V	500 ft-lb	20 rpm	R11-000-10
Pneumatic	500 ft-lb	26 rpm	R11-000-08
Hydraulic	500 ft-lb	24 rpm	R11-000-09
Electric 110V	500 ft-lb Vitals torque control	20 rpm	R11-000-17
Electric 220V	500 ft-lb Vitals torque control	20 rpm	R11-000-20
Hydraulic	500 ft-lb Vitals torque control	20 rpm	R11-000-19
Electric 110V	800 ft-lb	10 rpm	R11-000-02
Electric 220V	800 ft-lb	10 rpm	R11-000-05
Pneumatic	800 ft-lb	13 rpm	R11-000-03
Hydraulic	800 ft-lb	12 rpm	R11-000-04
Electric 110V	800 ft-lb Vitals torque control	10 rpm	R11-000-12
Electric 220V	800 ft-lb Vitals torque control	10 rpm	R11-000-15
Hydraulic	800 ft-lb Vitals torque control	12 rpm	R11-000-14

P-2 Handwheel Adapter

Size adjustable solution for using the P-2 with Standard Handwheels

MODEL	PART #
P-2 Handwheel Adapter	R11-401-00



P-2 Handwheel Adapter



RS2 Rising Stem Valve Operator electric model shown



RS2 Dedicated Handwheel Adapter P13-017-4007-00



RS2 Universal Handwheel Adapter P13-017-4008-00



P-2 Electric 110V Model



P-2 Pneumatic Model



P-2 Hydraulic Model

Hydraulic Power Units

DESCRIPTION	PART #
Gasoline HPU Model HCM-2G - 11 HP Honda gasoline engine driven Rated for 10 GPM @ 1500 PSI (37.9 LPM @ 103 BAR)	R14-000-08
Diesel HPU Model HCM-D23 - 23 HP diesel engine driven Rated for 15 GPM @ 1800 PSI (56.8 LPM @ 124 BAR)	R14-000-33
Electric HPU Model HCM-3E4-50 - 15 HP 415-440V 50Hz (IP44 rated) 3 phase 15 GPM @ 1500 PSI (56.8 LPM @ 103 BAR)	R14-000-28
Electric HPU Model HCM-3E3-50 - 15 HP 380V 50Hz (IP44 rated) 3 phase Rated for 15 GPM @ 1500 PSI (56.8 LPM @ 103 BAR)	R14-000-29
Heavy Duty Electric Model HPU-20 - 380-480v Electric Motor Driven Remote Controlled	R14-000-35

Hydraulic Hose Set & Accessories

DESCRIPTION	PART #
45 foot - 1/2in Hydraulic Hose Set W/Quick Disconnects (Not for use with Trav-L-Cutter)	R03-404-00
45 foot - 5/8in Hydraulic Hose Set includes 4 sets M/F Quick Disconnects. (For use with Trav-L-Cutter)	R02-408-00
20 Foot - 1/2in Hydraulic Hose Set	R09-406-00



Onsite Rentals

You may know that E.H. Wachs sells superior weld prep machine tools. You may also know that E.H. Wachs rents our equipment through our worldwide Sales, Service and Rental Centers. And that our rental fleet includes the Orbitalum line of orbital cutting and welding equipment. But what you may not know is Wachs offers a wide range of rental solutions, from daily, weekly or monthly rentals, to our innovative new WachsBox™ program.

Rentals are a great option for short term projects, where machines are used for a unique or one time job. But Rentals can also be a smart option for larger, major projects, where you need pipe cutting, beveling and flange facing machines day in and day out, often 24/7. For this scenario we invented the Wachs Box.

The WachsBox is a pre-stocked Conex delivered to the jobsite, preconfigured to your project needs, that remains onsite during your active field machining. The advantage of the WachsBox is that all the tools and tooling needed for onsite machining of pipe and vessels during a turnaround or MRO project are on the ground, ready for use at any time of the day or night.

Ask your local representative for more details about the modern way to rent E.H. Wachs weld prep machine tools and Orbitalum orbital cutting and welding systems, when and where you need them.

Need Training? Training is available at our location or yours.



Diesel D23 Hydraulic Power Unit



Electric Hydraulic Power Unit



WachsBox is your onsite rental solution



WachsBox is stocked with the tools you need for your project.



Training available at our location or onsite at yours

 Corporate Locations
★ Sales Locations

Contact your local ITW Orbital Cutting & Welding representative for additional information or to request a product demonstration.

UNITED STATES

ITW-OCW US Headquarters E.H. Wachs®

600 Knightsbridge Parkway
Lincolnshire, IL 60069 USA
T +1.847.537.8800
F +1.847.520.1147
Toll Free 800.323.8185

Northeast Sales, Service & Rental Center E.H. Wachs

1001 Lower Landing Road, Suite 208
Blackwood, New Jersey 08012 USA
T +1.856.579.8747
F +1.856.579.8748

Southeast Sales, Service & Rental Center E.H. Wachs

171 Johns Road, Unit A
Greer, South Carolina 29650 USA
T +1.864.655.4771
F +1.864.655.4772

West Coast Sales, Service & Rental Center E.H. Wachs

5130 Fulton Drive, Unit J
Fairfield, California 94534 USA
T +1.707.439.3763
F +1.707.439.3766

Gulf Coast Sales, Service & Rental Center E.H. Wachs

2220 South Philippe Avenue
Gonzales, LA 70737 USA
T +1.225.644.7780
F +1.225.644.7785

Houston (Pasadena) Sales, Service & Rental Center E.H. Wachs

3327 Daisy Street
Pasadena, Texas 77505 USA
T +1.713.983.0784
F +1.713.983.0703

GERMANY

ITW-OCW Europe Headquarters Orbitalum Tools GmbH® E.H. Wachs Sales & Service Center

Josef-Schüttler-Straße 17
Singen D78224 Germany
T +49 (0) 77 31 - 792 0
F +49 (0) 77 31 - 792 500

CANADA

Wachs Canada Ltd® Eastern Canada Sales, Service & Rental Center

1250 Journey's End Circle, Unit 5
Newmarket, Ontario L3Y 0B9
Canada
T +1.905.830.8888
F +1.905.830.6050
Toll Free 888.785.2000

Wachs Canada Ltd® Western Canada Sales, Service & Rental Center

5411 82 Ave NW
Edmonton, Alberta T6B 2J6
Canada
T +1.780.469.6402
F +1.780.463.0654
Toll Free 800.661.4235

UNITED KINGDOM

Wachs UK® UK Sales, Service & Rental Centre

Units 4 & 5 Navigation Park
Road One, Winsford Industrial Estate
Winsford, Cheshire CW7 3RL
United Kingdom
T +44 (0) 1606 861 423
F +44 (0) 1606 556 364

UNITED ARAB EMIRATES

Wachs Middle East & Africa Operations® E.H. Wachs

PO Box 262543
Jebel Ali Free Zone South
Dubai FZS 5, ACO6
United Arab Emirates
T +971 4 88 65 211
F +971 4 88 65 212

INDIA

ITW India Private Limited

Indialand Global Industrial Park
Sr. No.234/235/245, Plot 8, Gala No. 7
Hinjawadi-Phase-1
Tal-Mulshi, Pune 411057 India
T +91 40 30261812
F +91 40 30480815

CHINA

ITW Welding China E.H. Wachs / Orbitalum Sales

New Caohejing International Business Centre
Room 2801-B, Building B
No 391 Gui Ping Road
Shanghai 200052, China
T +86 (0) 21 52 30 37-51
F +86 (0) 21 52 30 37-58